



ROTORFLUSH SELF-CLEANING INTAKE

FILTERS & SCREENS

USE AND MAINTENANCE

INSTRUCTION MANUAL

**Models: RF600-200LW, RF600-300LW, RF600-400LW
RF600-500LW, RF600-600LW, RF600-700LW
RF600-800LW, RF600-900LW, RF600-1000LW**

TO BE KEPT BY THE USER

1.	MANUFACTURER AND PRODUCT IDENTIFICATION DATA	3
	Product Data	3
2.	TECHNICAL ASSISTANCE	3
3.	INTRODUCTION	3
4.	GENERAL SAFETY WARNINGS	4
	I. Preventive Measures to be taken by the User	4
	II. Significant Protection and Precautions	4
5.	DESCRIPTION	5
	I. General Description	5
	II. Dimensions and Characteristics	6
	III. Size and Capacity	7
	IV. Self-cleaning Filter Technical Data	7
6.	INTENDED AND UNINTENDED USE	8
	I. Intended Conditions of Use	8
	II. Unintended Conditions of Use	8
7.	HANDLING AND TRANSPORT	8
	I. Unpacking and handling	8
8.	INSTALLATION	9
	I. Features and Operation	9
	II. Siting the filter in the environment	10
	III. Mounting	11
	IV. Pipe Connections and setup	11
9.	PREPARATION FOR USE AND START UP	12
	I. Check rotation of Backwash Rotor	12
10.	MAINTENANCE AND REPAIRS	12
	I. Manual Cleaning of the filter screen	12
	II. Tightening the woven mesh	13
	IV. Replacement of rubber jets	Error! Bookmark not defined.
	V. Bearing replacement (see fig 4 for parts identification)	155
11.	TROUBLESHOOTING	16
12.	WASTE DISPOSAL	16
13.	Warranty	17
	I. Supply of spare parts	17
	II. Return of Filter to Rotorflush Filters Ltd	17
14.	NOTES	18

1. MANUFACTURER AND PRODUCT IDENTIFICATION DATA

Manufacturer Data

Rotorflush Filters Limited
The Workshop
Langmoor Manor
Charmouth
Bridport
Dorset
DT6 6BU
United Kingdom

Telephone: +44 (0) 1297 560229
Fax: +44 (0) 1297 560110
Email: mail@rotorflush.com

Product Data

Description:

- Rotorflush Self-Cleaning Suction Intake Strainer
- 316 Stainless steel woven tensioned filter mesh
- Filter body 304 or 316 stainless steel

Model references: RF600-200LW, RF600-300LW, RF600-400LW, RF600-500LW,
RF600-600LW, RF600-700LW, RF600-800LW, RF600-900LW,
RF600-1000LW

2. TECHNICAL ASSISTANCE

If a malfunction of the Filter is not covered in the TROUBLESHOOTING table (Section 12) contact Rotorflush Filters Ltd at the above address.

3. INTRODUCTION

This publication contains all necessary information and instructions for the use and maintenance of your Rotorflush Filter.

Follow the advice given to ensure correct operation and optimum performance of the Filter. For any other information, please contact Rotorflush Filters Ltd.

**THESE INSTRUCTIONS AND ILLUSTRATIONS ARE SUBJECT TO COPYRIGHT AND MUST NOT BE
COPIED IN WHOLE OR IN PART**

4. GENERAL SAFETY WARNINGS

FAILURE TO OBSERVE THESE WARNINGS AND/OR ANY TAMPERING WITH THE FILTER EXEMPTS ROTORFLUSH FILTERS LTD FROM ALL RESPONSIBILITY IN THE EVENT OF PERSONAL INJURY OR DAMAGE TO EQUIPMENT OR PROPERTY AND/OR TO THE FILTER.

Read this manual carefully and check to ensure that the Filter has been properly installed and connected in accordance with relevant safety standards before starting the Filter.

There are no RESIDUAL RISKS with Rotorflush Filters

No particular technical skills are required to use Rotorflush Filters (Although electrical installation should be carried out by a qualified electrician).

I. Preventive Measures to be taken by the User



The user must specifically comply with all the accident prevention regulations in force in the respective countries in which the Filter is being used; the indications given in Section 7 must be scrupulously followed.



During operation make sure that nobody is in the water. The user must not carry out under his/her own initiative any operations or tasks not contemplated in this manual.

II. Significant Protection and Precautions

Rotorflush Filters are designed so that all moving parts are shrouded by protective casings.

Rotorflush Filter Ltd declines all responsibility in the event of injury or damage caused as a result of tampering with these devices.

5. DESCRIPTION

I. General Description

Rotorflush RF600-LW Self-cleaning Pump Suction Intake Filters are all functionally similar with a common construction.

Models vary in weight, height and diameter according to their maximum flow rate. The standard outlet flange size is 8" (DN 200 PN16). Other sizes can be specified ahead of manufacture.

Rotorflush Filters are used for handling water containing low levels of suspended solids, such as those found in rivers and sea water (316 version). Unwanted solids are repelled from the filter screen by internal rotating cleaning jets keeping the mesh clear.

Rotorflush Filters are designed for long life, low maintenance and constant performance if used according to these instructions.

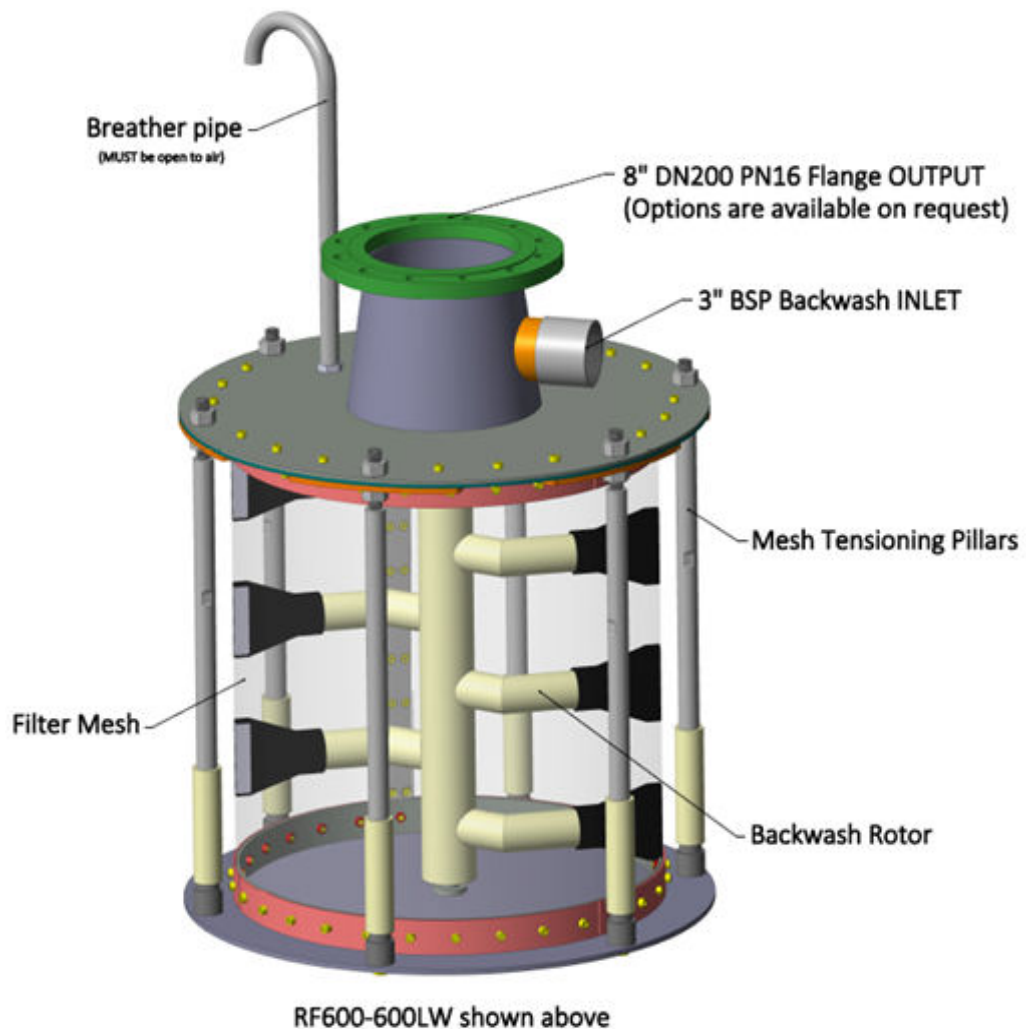

Figure 1

II. Dimensions and Characteristics

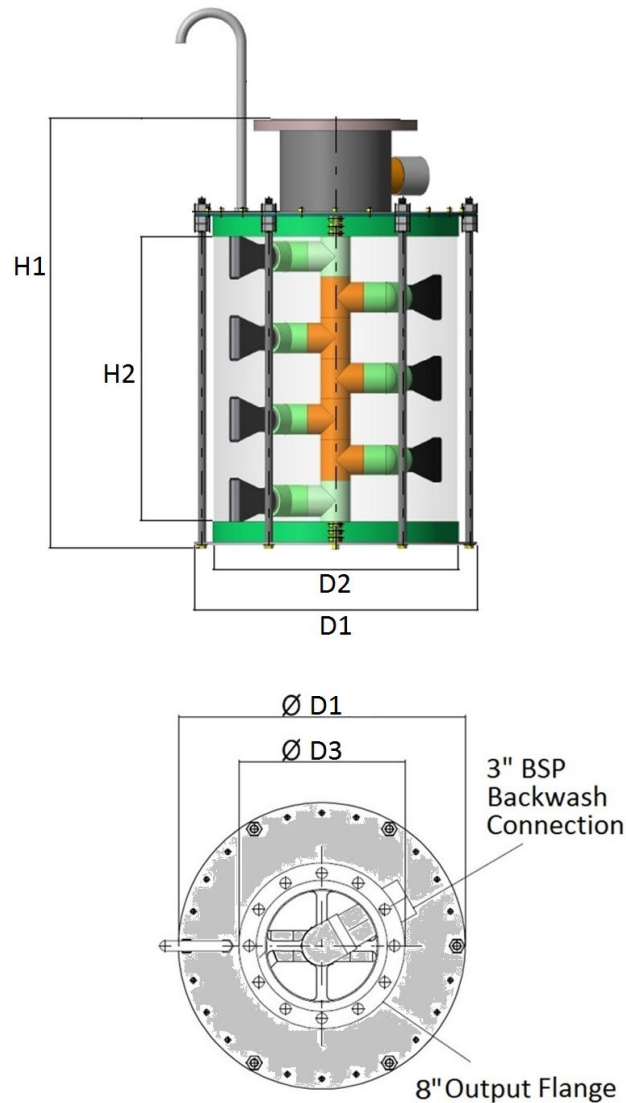

Figure 2

Model	H1 Total Approx. Height mm	H2 Mesh Approx Height mm	D1 Total Diameter mm	D2 Mesh Diameter mm	D3 Flange Diameter mm
RF600-200LW	555	200	750	600	340
RF600-300LW	655	300	750	600	340
RF600-400LW	755	400	750	600	340
RF600-500LW	855	500	750	600	340
RF600-600LW	955	600	750	600	340
RF600-700LW	1055	700	750	600	340
RF600-800LW	1155	800	750	600	340
RF600-900LW	1255	900	750	600	340
RF600-1000LW	1355	1000	750	600	340

III. Size, Capacity & Weight*

Model	Filter screen Area cm ²	Maximum Flow Rate m ³ /hr (net of backwash)	<u>Eel Regulations</u> Flow rate velocity (net of backwash) m ³ /hr @ 0.1 m sec	Backwash Flow Rate m ³ /hr	Backwash Pressure	Approx Weight Kgs (Dry)
RF600-200LW	3,770	160	81	9	0.4 bar	80
RF600-300LW	5,655	240	122	13.5	0.4 bar	90
RF600-400LW	7,540	320	162	18	0.4 bar	100
RF600-500LW	9,425	400	203	22.5	0.4 bar	110
RF600-600LW	11,310	480	244	27	0.4 bar	120
RF600-700LW	13,195	560	285	31.5	0.4 bar	130
RF600-800LW	15,080	640	325	36	0.4 bar	140
RF600-900LW	16,965	720	366	40.5	0.4 bar	150
RF600-1000LW	18,850	800	407	45	0.4 bar	160

*Dimensions and weights based on Filters fitted with a 8" DN200 outlet Flange

IV. Self-cleaning Filter Technical Data

Filter Component	Construction
Filter mesh	316 stainless steel
Filter uprights	304 or 316 stainless steel
Filter top and bottom plate	304 or 316 stainless steel
Top and bottom plate bolts & fastenings	304 or 316 (A2 or A4) stainless steel
Tensioning nuts, 6 x M20, 15mm thick	Phosphor bronze PB 102
Cleaning Rotor	304 or 316 Stainless steel or ABS
Rotor bearings	Acetal
Top and Bottom Rotor bearings	304 or 316 Stainless steel
Rubber jets	Natural Rubber or food grade rubber
Rubber jet clips	304 or 316 Stainless steel
Lifting Eyes	304 or 316 Stainless steel
ANSI top flange	304 or 316 stainless steel, standard is 8" DN200 PN16, other sizes may be fitted
ANSI Backwash connection	316 stainless steel, 3" BSP
Tensioning assemblies	Core: Hi-tensile Steel, Delta Tone 9000® inorganic, non - electrolytically applied micro layer zinc - Lamella flake coating Housing: 304 or 316 stainless steel

6. INTENDED AND UNINTENDED USE

WARNING



Failure to respect the prescribed limits constitutes a situation of use that is technically improper and may endanger the safety of persons and thus **EXEMPTS ROTORFLUSH FILTERS LTD FROM ANY RESPONSIBILITY IN THE EVENT OF ACCIDENTS TO PERSONS OR DAMAGE TO EQUIPMENT OR PROPERTY AND/OR TO THE FILTER, THEREBY RENDERING THE GUARANTEE INVALID.**

I. Intended Conditions of Use

Rotorflush Filters are suitable for filtering water with low levels of suspended solids; Oily/fatty/sticky solids will reduce filter performance.

II. Unintended Conditions of Use

Rotorflush Filters should not be installed in swimming pools and similar environments. Rotorflush self-cleaning filters **MUST NOT BE USED** for pumping water containing acids and corrosive liquids in general, or in water with temperatures over 45°C, or for filtering inflammable liquids or dangerous liquids in general.

7. HANDLING AND TRANSPORT

I. Unpacking and handling



Move the pallet containing the filter to the site where it is to be installed before unpacking.

Check that there are no breakages or dents in the packing; if there are, point this out immediately to the person who delivers the unit.

Carefully remove any packing material around the outside of the filter. While it is still resting on the pallet, check that there has been no damage to the filter during transport, paying particular attention to the filter mesh. Carefully put your arm in through the flange and check to see if the rotor can be rotated by hand, it should rotate without excessive force. If it will not rotate or requires a lot of force then the filter may have been damaged during transit.

If there is any damage contact Rotorflush Filters Ltd for advice

If no damage is observed the filter can now be lifted off the base of the pallet. This must be done by attaching suitable chains or lifting gear to the lifting eyes and slowly lifting the filter with a suitable lifting device.

THE FILTER MUST NOT BE MOVED WITH ANYTHING THAT PUTS FORCE ON THE FILTER MESH

8. INSTALLATION



BEFORE CARRYING OUT ANY INSTALLATION OPERATIONS:

Ensure that all relevant **safety procedures** are observed. Particular care should be taken when moving the filter. The filter is heavy and only persons experienced and suitably qualified must attempt installation.

I. Features and Operation

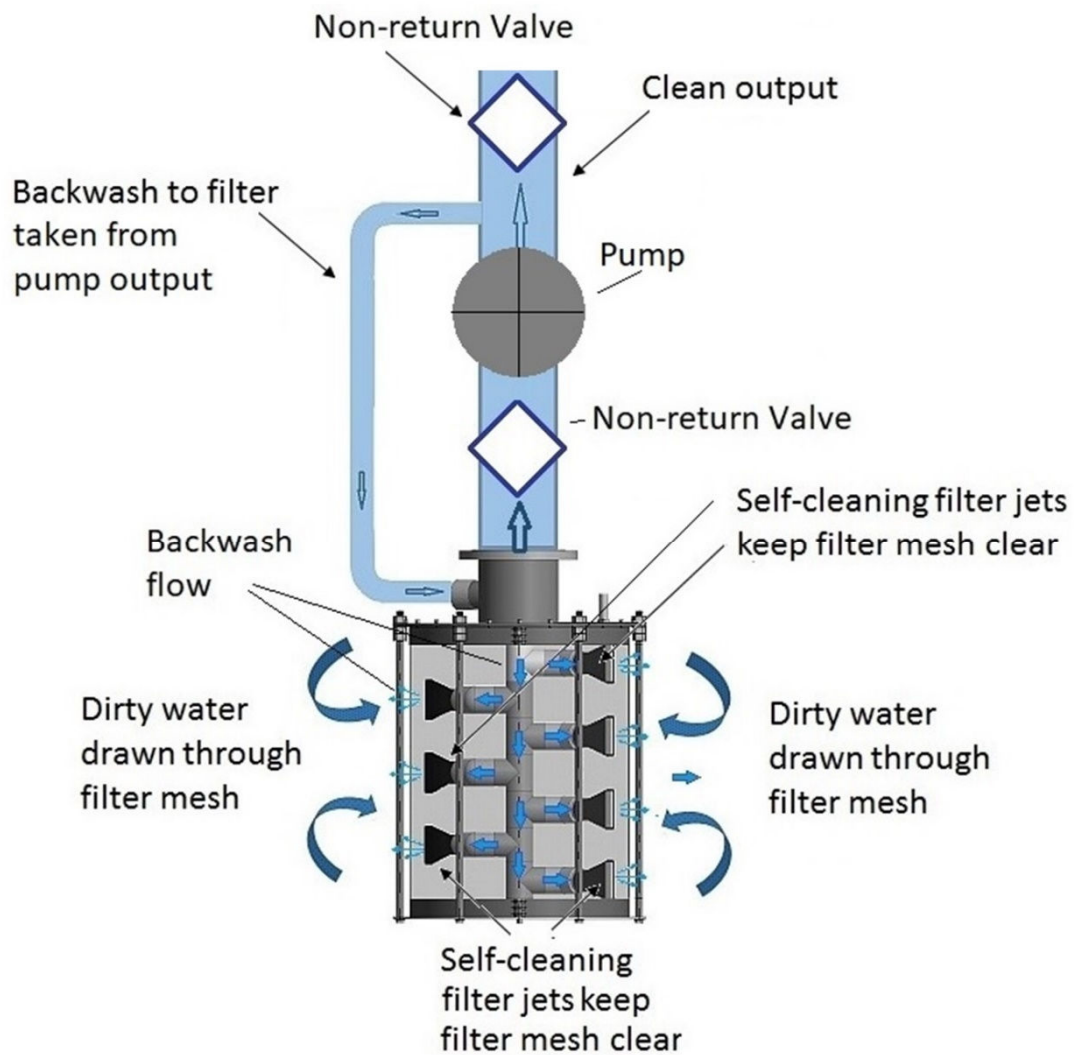

Figure 3

II. Siting the filter in the environment

The filter can be sited in tanks, ponds/lagoons, rivers/streams and channels/flumes and seawater (316 stainless steel version) where it is immersed in water.

It is very important that the detritus backwashed from the filter has sufficient space to move away from the filter.

It is not advised to put any pre-screening devices around the filter. Debris will be trapped between the pre-screening device and the filter; this may build up and block the filter.

Flowing water

When installing the filter in flowing water, (in rivers/streams, channels/flumes, where the flow is great enough to stop settlement of solids), space around the filter is not necessarily as important. Detritus backwashed from the filter will be carried away downstream by the flow.

The filter should have enough space around it to allow a flow of water all around it to take backwash solids away from the screen.

When siting in a channel with flowing water, there should be at least 0.3 metres each side of the filter and the channel wall.

The filter may need protection to stop build-up of weed, logs and detritus that may be brought down by the flowing water and collect around the filter and put undue force on the outlet connection. Any such protection should be sited so that it does not stop the flow of water around the filter taking backwashed debris downstream.

Tanks, Ponds, Lagoons

When siting in a tank or pond/lagoon, detritus backwashed from the filter will build up in the tank or pond/lagoon. Periodically this detritus will need to be removed. To allow the filter to work for as long as possible in the tank before cleaning out is required, it is important that there is sufficient space around and below the filter for detritus to move away and settle.

In some circumstances the detritus may float and form a crust on the water in the tank or lagoon; in this situation the filter should be sited with enough water above it so that a crust can form away from the filter.

The filter must have as much space to the sides and below the filter as possible to allow detritus to move away from the filter screen. The smaller the clearance around the filter unit the more frequently the tank, pond or lagoon will need to have the detritus removed, usually by emptying it.

***CARE MUST BE TAKEN NOT TO DAMAGE THE FILTER UNIT WHEN REMOVING*
ACCUMULATED DEBRIS**

III. Mounting

Lifting eyes allow the filter to be lifted vertically.

With solid steel piping the filter can be secured vertically by the top flange.

When using flexible piping the filter can be rested on a stand so that the filter base is not resting on the bed or in silt. In this case the filter may need to be secured from being moved by any current at the location using the lifting eyes at the top of the filter.

It is the installer's responsibility to ensure that the pipework connected to the outlet flange is strong enough to withstand forces created from any water flowing past the filter.

The Filter must be submerged in the water by a minimum of 200mm above top of the Filter area. If the water is turbulent or there is any likely hood of water level dropping then the installer must install the Filter deeper under the water. There must be at least 200mm clearance below the filter. The filter can be suspended or on a stand to ensure that the base of the filter is above any debris, mud, sand etc.

IV. Pipe Connections and setup

Connect the suction pipe from the pump to the outlet flange. Normally a non-return valve should be fitted in the suction line near to the filter to make sure the main pump that the filter is connected to remains primed.

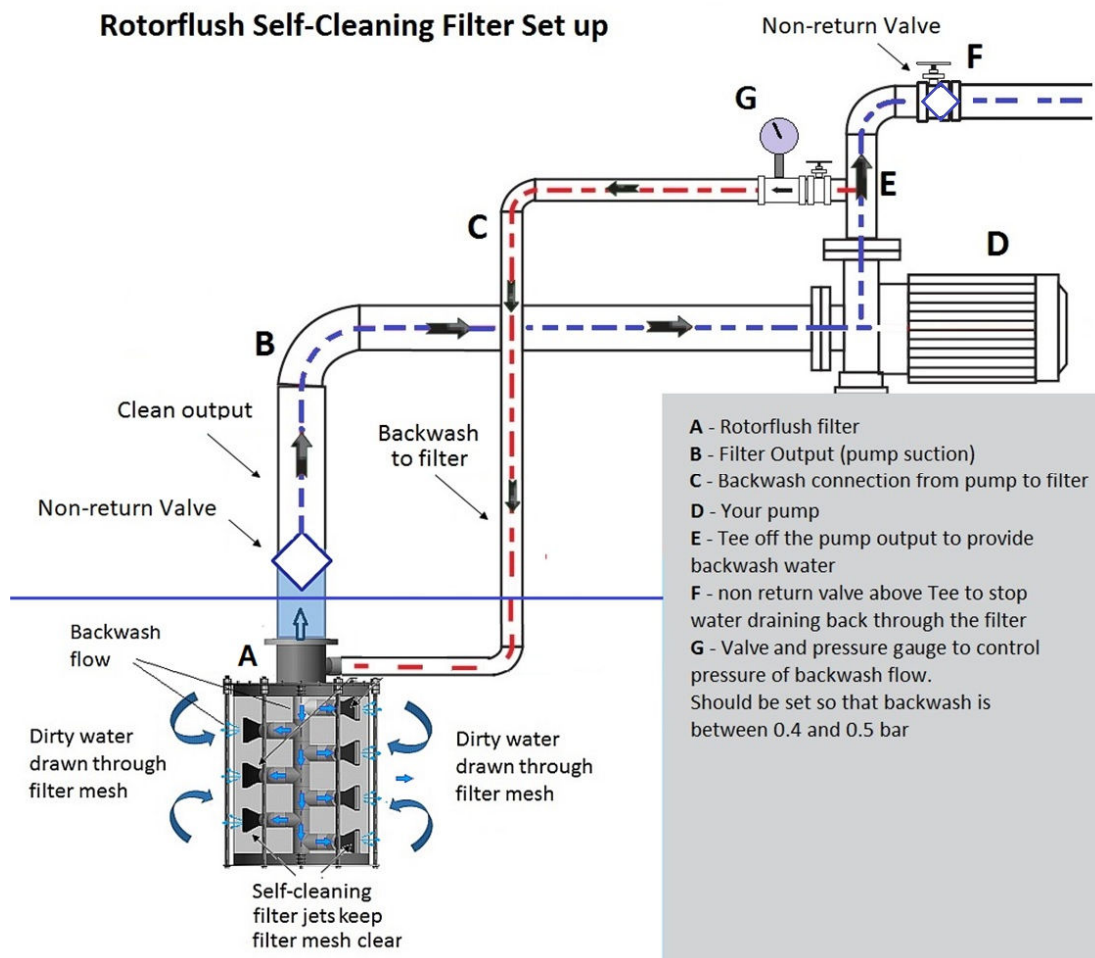

9. PREPARATION FOR USE AND START UP

Fill the pipe from the pump intake to the filter with water and prime your main pump. Check that it is safe to start the pump.

Systems pressure greater than 0.6 bars

If the system pressure will be greater than 0.6 bars when the pump is running, close the valve on the backwash pipe so that no water is delivered to the backwash pipe. Check that it is safe to start the pump. Start the pump; once it is pumping water slowly open the valve so that the pressure gauge is reading between 0.4 and 0.6 bars.

System pressure less than 0.4bars

If the system pressure is less than 0.4 bars when the pump is running then the throttling valve should be installed upstream of the TEE and should be set so that it increases the pressure in the backwash pipe to between 0.4 and 0.6 bars. Check that it is safe to start the pump. Start the pump, once pumping slowly close the throttling valve so that the pressure gauge is reading between 0.4 and 0.6 bars.

I. Check rotation of Backwash Rotor

If the water is clear enough you may be able to see the backwash jets in operation. The rotor rotates clockwise when viewed from above at approximately 20 RPM. A jet will pass a fixed vertical line on the screen approximately every 3 seconds.

10. MAINTENANCE AND REPAIRS

BEFORE CARRYING OUT ANY MAINTENANCE OPERATIONS:



Turn off main pump and make sure that all relevant safety procedures are observed.



Particular care should be taken when uninstalling the filter. The filter is heavy and only persons experienced and suitably qualified must attempt to lift it.

Remove the filter from the water. Note when full of water this is heavy, remove slowly to allow to drain. When removing the filter from the water use suitable lifting gear; ONLY suitable lifting gear must be attached to the lifting eyes, and ALL lifting eyes must be used for lifting.

Once removed from the water, the filter must be stabilised.

I. Manual Cleaning of the filter screen

The filter screen should be lifted and inspected periodically to check that it is clean. It is possible for organisms to attach to the filter screen that are not removed by the backwashing jets.

The frequency of manual cleaning is very variable and depends on the conditions pertaining in the water, such as temperature, nutrient content and organisms present. We recommend at least annual maintenance of the screen, possibly more frequently.

The screen must be pressure washed clean. Pressure washing may need to be more frequent if the water is very dirty. The woven mesh screen is robust and should be cleaned by using high pressure water jets. Make sure that the mesh is completely clear of debris after cleaning.

NB: The filter mesh is held under tension. It is highly unlikely but over time the mesh may require re-tightening.

II. Tightening the woven mesh

The filter mesh is under tension. It is kept taut by compression springs at the base of each of the six support pillars around the perimeter of the filter. Each spring is tensioned to 332kg, making a total tension of 2000kg on the mesh of each filter.



DO NOT ATTEMPT TO REPLACE THE FILTER MESH

Should the mesh ever need to be replaced or repaired the filters must be returned to Rotorflush Filters Ltd

NB: loosen each nut and it's opposite in turn and likewise when tensioning.

Remove lifting eye bolts. Loosen the Stainless Steel M20 nuts on the top Flange plate. **Do not remove the Top Plate.**

The Phosphor Bronze M20 nuts below the plate when turned anti-clockwise will tighten the mesh. Using a 33mm spanner turn each Phosphor Bronze nut below the Top Support Plate half a turn anti-clockwise. Use a 26mm spanner to stop the Support Pillars rotating.

If any maintenance on the mesh is required on site, the Phosphor Bronze M20 nuts below the Top Plate must be turned in a clockwise direction (as viewed from above) until they run freely and all tension on the mesh is released.

Go around the Filter turning each one and it's opposite by the same amount until the mesh is tight.

**Do not over tighten the mesh – Manufacture's setting - Gap Measurement 9.0 mm
(See Fig5)**

When mesh is tensioned using a 33mm spanner, tighten each Stainless-Steel nut above the Top Plate clockwise until all the retaining Stainless Steel nuts are secure.

IV. Replacement of Rubber Jets

Over time the rubber backwashing Jets may need replacement. Normally we would advise replacement every 4 years. The Filter system will need to be removed from the water.

**Replacement Jet sets are available from Rotorflush Filters Ltd.*

Pay particular attention to the distance from the Jets to the Filter Mesh. Note also the direction the Jet Clips are facing as this is critical for ensuring that the Backwash Rotor rotates in the correct direction (clockwise when viewed from above).

Release the mesh tension as described in 10 II above.

- 1) Remove the 8mm cap head screws, Lifting Eyes and the 20mm nuts from the top Flange plate and Filter and remove the Top Plate and Flange. Pull out the cleaning Rotor, being aware of the cut outs in the support plate below the Top Plate which allow the Backwash Rotor to be removed.
- 2) Each Rubber Jet is held in place with a Jubilee Clip. Loosen the Jubilee Clip using a standard flathead screw driver and / or 7mm spanner. Remove the old Rubber Jet and Jubilee Clip.
- 3) Put the Jubilee Clip onto the 50mm pipe and then push the new Rubber Jet onto the pipe.
NB: The Jet Shaping Clip in the end of the Rubber Jet must be positioned as shown in Fig 4

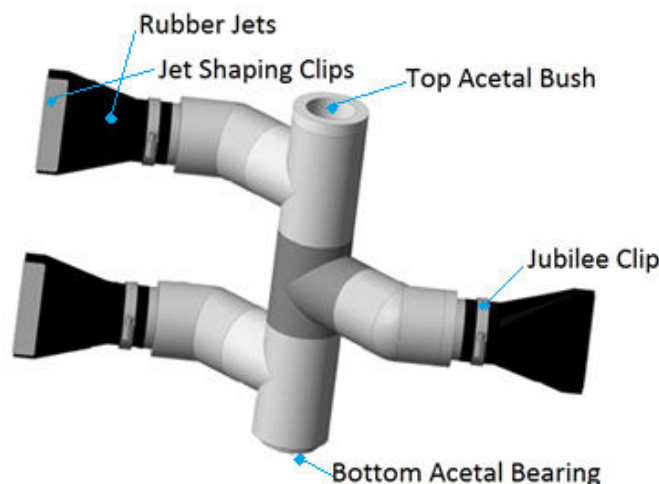

Figure 4

There should be a gap of 10-12mm (critical dimension) between the end of the Jet and the inside of the Filter Mesh.

- 4) Reverse the process & re-apply tension to the mesh measuring the gap at the base of the tensioning pillars to 9.0 mm as shown in fig 5.

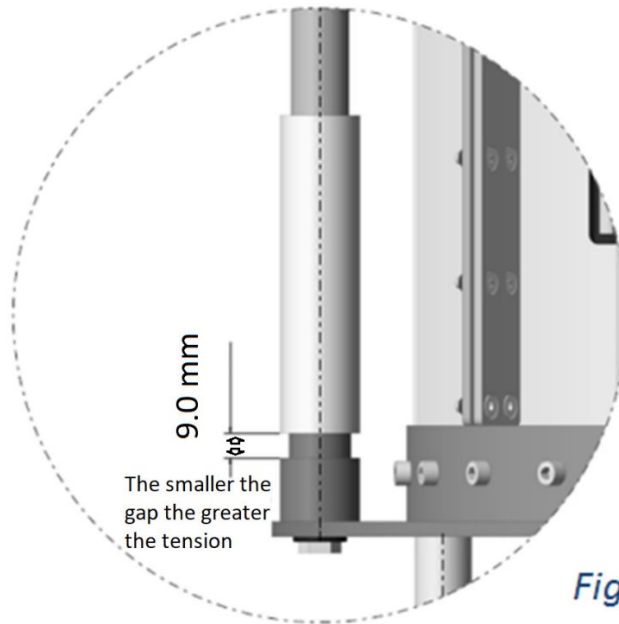

Figure 5

5) Once the mesh has been tensioned evenly around the filter re-tighten the stainless steel M20 locking nuts and re fit the eyebolts into the filter top plate.

V. Bearing replacement (see fig 4 for parts identification)

There are Acetal bearings in both ends of the central rotor tube.

**Bearing sets are supplied by Rotorflush Filters Ltd.*

Remove the self-tapping screws that hold the bearings in place.

Insert a long rod through the hole in the top Acetal bearing and tap the bottom bearing out.

Do the same from the opposite end for the Acetal top bearing.

Tap the new bearings into the tube ensuring they go in flush and square and replace the retaining bolts.

The bottom bearing post is retained by an M10 bolt through the centre of the bottom plate.

Remove the bolt and take out the old bearing post. Install the new bearing post.

The top bearing spigot is screwed through the top plate into a 3" to 2" reducer.

Unscrew the top bearing spigot from the reducer and install the new one.

**All parts are available from Rotorflush Filters Ltd*

11.TROUBLESHOOTING

FAULT	CAUSE	REMEDY
Filter blocks causing pump to cavitate and /or stop pumping water	Solids levels in the water too high	If in a tank or pond with no flow, drain the tank or pond and re-fill. If solid levels persistently high reduce the pump's output. Where there is water flowing past the filter, reduce the pump's output.
	Screen is contaminated with organisms growing on the screen or detritus attached to the screen that is not removed by the backwash	Clean the screen (see 10 ii)
	Rubber jets split	Replace rubber jets (see 10 iv)
	Backwash Rotor not rotating	Check that backwash pump is operating Filter rotor bearings worn, replace bearings (see 10 v)
Filter blocked and pump will not pump water when started again.	When the filter screen is blocked, with the pump running, the differential pressure across the screen will be too great for the backwash jets to clear the screen	Stop the pump and clean the screen manually.

12.WASTE DISPOSAL

See 5 iv for materials of construction. Remove rubber jets, Acetal bearings and Tensioning assemblies and dispose of/recycle safely.

The remainder of the filter is 304/316 Stainless Steel and Phosphor Bronze which can be recycled.

13. WARRANTY

The warranty period is 12 months from delivery.

I. Supply of spare parts.

Spare parts will be delivered without charge, within the warranty period, to mainland UK addresses only.

If the customer exports the filter outside the United Kingdom there will be a charge for delivery of the spare parts.

II. Return of Filter to Rotorflush Filters Ltd.

If within the warranty period the customer returns the Filter(s), to Rotorflush Filters Ltd then Rotorflush will undertake repairs without charge.

Rotorflush will deliver the repaired filter without charge within the warranty period to mainland UK addresses only.

If the customer exports the filter outside the United Kingdom, there will be charge to return the filter to the customer.

DECLARATION OF CONFORMITY

DECLARATION OF CONFORMITY

We, ROTORFLUSH FILTERS LIMITED, declare under our own responsibility that our Self-cleaning Suction Intake Filters models

RF600-200LW, RF600-300LW, RF600-400LW, RF600-500LW, RF600-600LW, RF600-700LW, RF600-800LW and RF600-900LW conform to the Machinery Directive 2006/42/EC.

The relevant parts of the following standards apply:

BS EN ISO 12100:2010 Safety of machinery - General principles for design - Risk assessment and risk reduction.

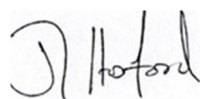



14.NOTES