



rotorflush

**USE AND MAINTENANCE
INSTRUCTION MANUAL for
ROTORFLUSH FILTERS**

Self Cleaning Pump Intake Filters and Screens

Model RF400AR-E

TO BE KEPT BY THE USER



rotorflush

www.rotorflush.com

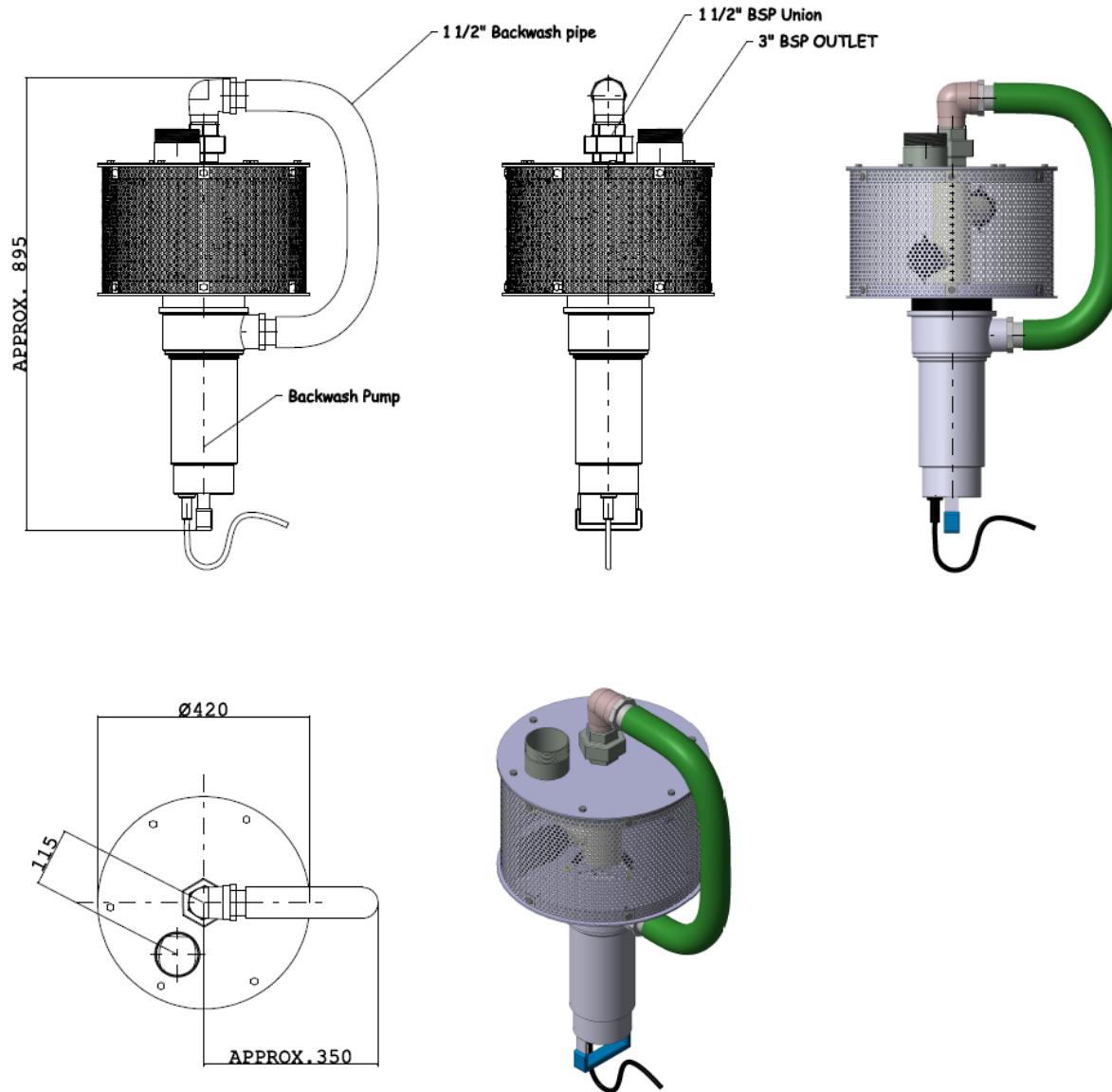

1. **MANUFACTURER AND FILTERPUMP IDENTIFICATION DATA**

1.1. **Manufacturer Data**

Rotorflush Filters Limited

Langmoor Manor

Charmouth

Bridport

Dorset

DT6 6BU

United Kingdom

Telephone: +44 (0) 1297 560229

Fax: +44 (0) 1297 560110

Email: mail@rotorflush.com

1.2 **Filter Data**

Description: Self Cleaning Pump Intake Filter/Strainer

2. **TECHNICAL ASSISTANCE INFORMATION**

If a malfunction of the Filter is not covered in the TROUBLESHOOTING table (Section 12) contact Rotorflush Filters Ltd at the above address.

3. **INTRODUCTION**

This publication contains all necessary information and instructions for the use and maintenance of your Rotorflush Filter

Follow the advice given to ensure correct operation and optimum performance of the Filter. For any other information, please contact Rotorflush Filters Ltd.

THESE INSTRUCTIONS AND ILLUSTRATIONS ARE SUBJECT TO COPYRIGHT AND MUST NOT BE COPIED IN WHOLE OR IN PART

4.

CONTENTS

1. Manufacturer and Machine Identification Data

2. Information on Technical Assistance

3. Introduction

4. Contents

5. General Safety Warnings

5.1. Preventive measures to be taken by the user

5.2. Significant protection and precautions

6. Description

6.1. General description

6.2. Technical and construction features

7. Intended Use and Unintended Use

7.1. Intended conditions of use

7.2. Unintended conditions of use

8. Handling and Transport

9. Installation

9.1 Siting the filter in the environment

9.2 Mounting

9.3 Pipe Connections

9.4 Pump Protection

10 Preparation for Use and Start up

10.1 Check rotation of backwash Jets

11 Maintenance and repairs

11.1 Manual Cleaning of the filter screen

11.2 Replacement of rubber jets

11.3 Bearing replacement

12 Troubleshooting

13 Waste Disposal

14. Warranty

5. GENERAL SAFETY WARNINGS

FAILURE TO OBSERVE THESE WARNINGS AND/OR ANY TAMPERING WITH THE FILTER EXEMPTS ROTORFLUSH FILTERS LTD FROM ALL RESPONSIBILITY IN THE EVENT OF PERSONAL INJURY OR DAMAGE TO EQUIPMENT OR PROPERTY AND/OR TO THE FILTER.

Read this manual carefully and check to ensure that the Filter has been properly installed and connected in accordance with relevant safety standards before starting the Filter.

There are no RESIDUAL RISKS with Rotorflush Filters

No particular technical skills are required to use Rotorflush Filters

5.1 Preventive Measures to be Taken by the User



- a) The user must specifically comply with all the accident prevention regulations in force in the respective countries in which the Filter is being used; the indications given in Section 7 must be scrupulously followed.
- b) **During operation make sure that nobody is in the water**
The user must not carry out under his/her own initiative any operations or tasks not contemplated in this manual.

5.2 Significant Protection and Precautions

Rotorflush Filters are designed so that all moving parts are shrouded by protective casings. Rotorflush Filter Ltd declines all responsibility in the event of injury or damage caused as a result of tampering with these devices.

6 DESCRIPTION

6.1 General Description

Rotorflush self cleaning pump intake filters are all similar from the functional and constructive point of view; the only differences are the following:

- flow rate
- weight
- dimensions

Rotorflush Filters are used for handling water containing low levels of suspended solids as found in rivers and sea water (316L version) Unwanted solids are repelled from the filter screen by rotating internal jets. The jets are powered by taking a Tee off the pumps output pipe and connecting it to the backwash connection at the top of the filter.

Rotorflush Filters are designed for long life and constant performance if used according to these instructions.



6.1 (continued)

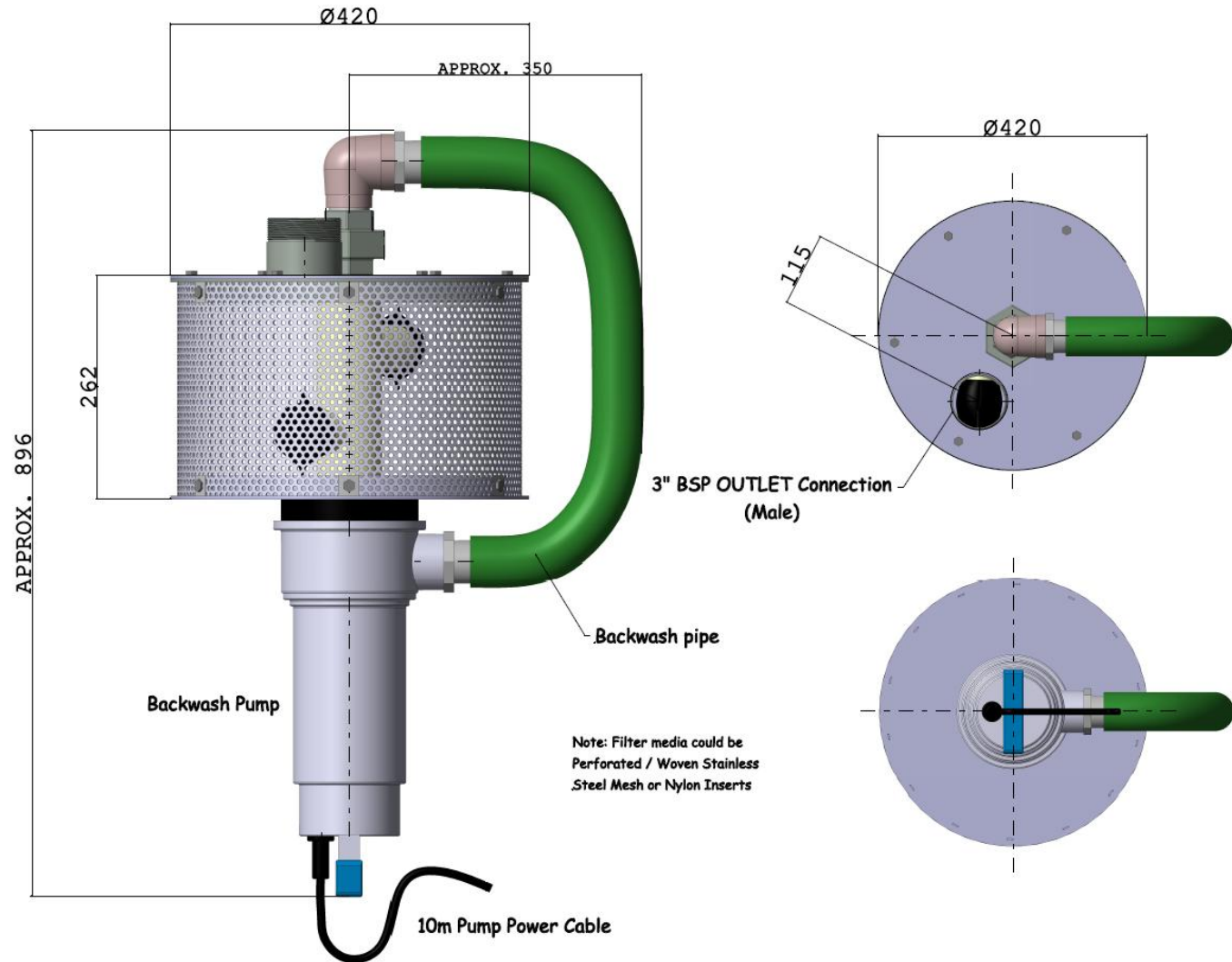

Fig 1

6.2 Self-cleaning Filter Technical Data

Filter screen Area RF400R		2500 cm ²
Filter Mesh		3 mm or 6mm aperture perforated 316 stainless steel
Materials: Filter body		304 stainless steel (316 for sea water)
Rotor bearings		304 stainless/acetal (316 for sea water)
Rubber jets		Natural rubber
Rubber jet clips		304 stainless steel (316 for sea water)
3 inch nipple		316 stainless steel
Maximum usable flow		60m ³ /hr
Backwash pump 230v single phase 50 Hz 0.75 kW		Full load current 5.7 amps
Backwash pump 415v 3 phase 50Hz 0.75 kW		Full load current 2.6 amps
Weight RF400RE		19.00 kg

7 Intended and Unintended Use

WARNING



Failure to respect the prescribed limits constitutes a situation of use that is technically improper and may endanger the safety of persons and thus EXEMPTS ROTORFLUSH FILTERS LTD FROM ANY RESPONSIBILITY IN THE EVENT OF ACCIDENTS TO PERSONS OR DAMAGE TO EQUIPMENT OR PROPERTY AND/OR TO THE FILTER, THEREBY RENDERING THE GUARANTEE INVALID.

7.1 **Intended Conditions of Use**

Rotorflush Filter are suitable for filtering water with low levels of suspended solids, Oily/fatty/sticky solids will reduce filter performance.

7.2 **Unintended Conditions of Use**

Rotorflush Filters must not be installed in swimming pools and similar environments, for pumping water containing acids and corrosive liquids in general, water with temperatures over 45°C, inflammable and dangerous liquids in general.

8. **HANDLING AND TRANSPORT**

Unpacking and handling



Move the box containing the filter to the site where it is to be installed before unpacking

Check that there are no breakages or dents in the packing; if there are, point this out immediately to the person who delivers the material. Open the box, check that there has been no damage to the filter during transport, paying particular attention to the filter mesh.

9. **INSTALLATION**



BEFORE CARRYING OUT ANY INSTALLATION OPERATIONS.

Ensure that all relevant safety procedures are observed. Particular care should be taken when moving the filter. The filter is heavy and only persons experienced and suitably qualified must attempt installation.

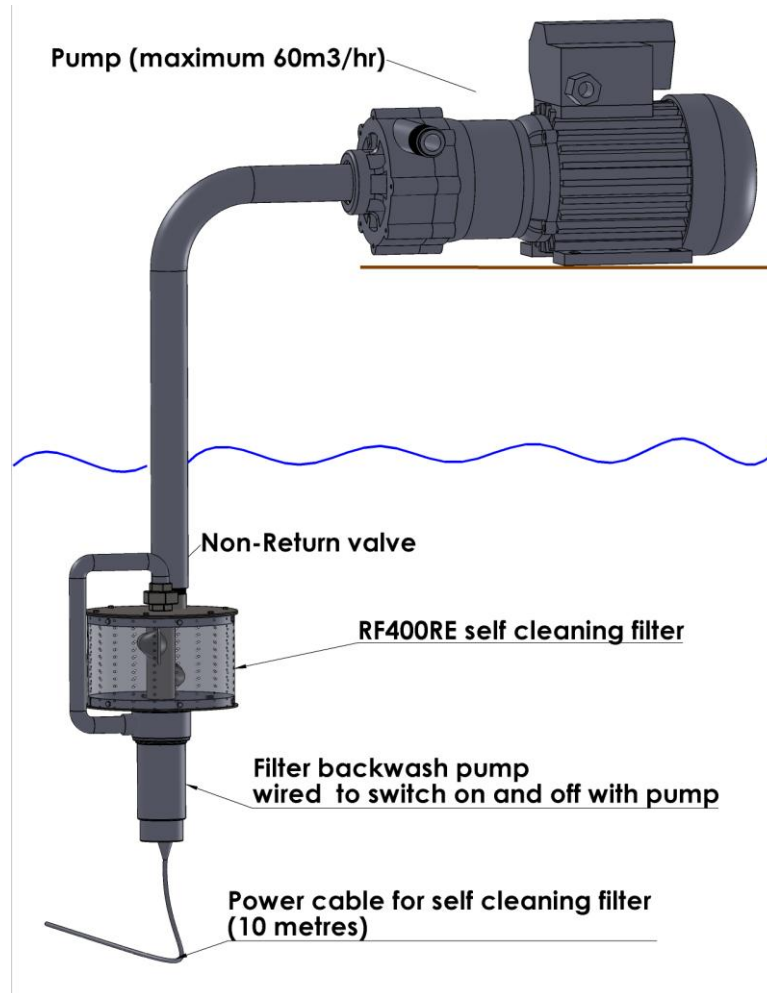

FIG 2

9.1 Siting the filter in the environment

The filter can be sited in tanks, ponds/lagoons, rivers/streams and channels/flumes where it is immersed in water.

It is very important that the detritus backwashed from the filter has sufficient space to move away from the filter.

It is not advised to put any pre-screening devices around the filter. Debris will be trapped between the pre-screening device and the filter; this may build up and block the filter.

9.1.1 Flowing water

When installing the filter in flowing water, (in rivers/streams, channels/flumes, where the flow is great enough to stop settlement of solids), space around the filter is not as important. Detritus backwashed from the filter will be carried away downstream by the flow. The filter should have enough space around it to allow a flow of water all around it to take backwash solids away from the screen.

When siting in a channel with flowing water, there should be at least 0.3 metres each side of the filter and the channel wall.

The filter may need protection stop build up of weed, logs and detritus that may be brought down by the flowing water and collect around the filter and put undue force on the 3 inch pipe nipple. Any such protection should be sited so that it does not stop the flow of water around the filter taking backwashed debris downstream.

9.1.2 Tanks ponds/lagoons

When sitting in a tank or pond/lagoon, detritus backwashed from the filter will build up in the tank or pond/lagoon. Periodically this detritus will need to be removed. To allow the filter to work for as long as possible in the tank before cleaning out is required, it is important that there is sufficient space around and below the filter for detritus to move away and settle. In some circumstances the detritus may float and form a crust on the water in the tank, in this situation the filter should be sited with enough water above it so that a crust can form away from the filter.

The filter must have as much space to the sides and below the filter as possible to allow detritus to move away from the filter screen. The smaller the clearance around the filter unit the more frequently the tank, pond or lagoon will need to have the detritus removed usually by emptying it.

9.2 Mounting

The filter is designed to be supported by the top 3 inch pipe nipple. It should be mounted with the 3 inch flange at the top as shown in fig 2. A non-return valve (NRV) should be installed to the 3 inch nipple. We are also able to provide lifting eyes if required. In this case the filter can be hung from the 3 lifting eyes.

It is the installers responsibility to ensure that the pipework connected to the 3 inch nipple is strong enough to support the weight of the filter and forces created from the water flowing past the filter.

The filter must be submerged in the water by a minimum of 200 mm above top of the filter screen (see Fig 2 page 10). If the water is turbulent or there is any likely hood of water level dropping then the installer must install the filter deeper under the water.

It is important that the backwash pump is fully submerged for cooling the motor.



9.3 Pipe Connections.

Connect the suction pipe from the pump to the 3 inch pipe nipple (see fig 2 page 10). Normally a non- return valve should be fitted in the suction line near to the filter to make sure the main pump that the filter is connected to, does not lose prime.

9.4. The filter backwash pump must be connected by a qualified electrician. The backwash pump must be connected so it is switched on and off at the same time as the main pump that the filter is connected to. The backwash pump can be started direct online but overload protection must be provided.



9.5 Main Pump and filter backwash pump protection



In some situations the filter may become blocked, either by high levels of solids in the water, insufficient flow past the filter to take backwashed solids away from the filter (see 9.1.1, page 11) or build up of solids when installed where there is no flow past the filter (see 9.1.2, page 11). See Trouble Shooting (see section 12 page 17)

If the filter becomes blocked or partially blocked it may cause the pump to cavitate or run dry. To protect the pump from damage it is strongly advised that equipment is installed to detect that the pump is cavitating or running dry and automatically shut the main pump down **and also to shut the filter backwash pump down.**

10. PREPARATION FOR USE AND START UP

Fill the pipe from the pump intake to the filter with water and prime the pump.

10.3 Check rotation of backwash Jets

If the water is clear enough you may be able to see the backwash jets in operation. The rotor rotates at approximately 20 RPM. As there are two jets for each section backwashed, a jet will pass a fixed point on the screen approximately every 1.5 seconds

11. MAINTENANCE AND REPAIRS



BEFORE CARRYING OUT ANY MAINTENANCE OPERATIONS.

Turn off main pump and filter backwash pump and make sure that all relevant safety procedures are observed. Particular care should be taken when uninstalling the filter. The filter is heavy and only persons experienced and suitably qualified must attempt to lift it

Remove the filter from the water. Note when full of water this is heavy, remove slowly to allow to drain. Once removed from the water, the filter must be stabilised by the use of chocks.

Weights

RF400RE full of water 50 kg.

11.1 Manual Cleaning of the filter screen

The filter screen should be inspected periodically to check that it is clean. It is possible for organisms to attach to the filter screen that are not removed by the backwashing jets. The frequency of manual cleaning is very variable and depends on the conditions pertaining in the water, such as temperature, nutrient content and organisms present.

If the screen is severely contaminated it may require the filter to be removed from the water. The perforated stainless screen is robust and can be cleaned by using high pressure water jets. Make sure that the 3 or 6mm perforations are completely clear of debris after cleaning.

11.2 Replacement of rubber jets

Over time the rubber backwashing jets will need replacement. Normally we would advise replacement every 4 years. The filter system will need to be removed from the water.

1. Unscrew the bolts securing the top plate (see fig 4)
2. Lift out the cleaning rotor
3. Each rubber jet is held in place with a hose clamp. Loosen the hose clamp using a standard screw driver and/ or 7mm spanner. Remove the old rubber jet and hose clamp (*Note retain hose clamp for re-use*)
4. Put the hoseclamp onto the 50mm pipe, then push new rubber jet onto pipe, **the metal clip in the end of the rubber jet must be positioned as shown in Fig 3.** There should be a gap of 10mm between the end of the jet and the inside of the filter casing.

Fig 3

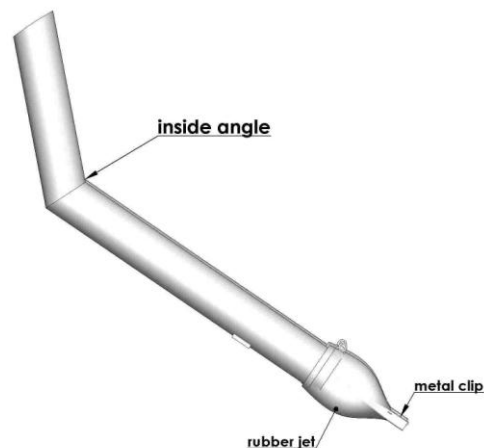

When installing rubber jets metal clip must be on inside angle of pipe as shown. Incorrect installation will stop rotor rotating.

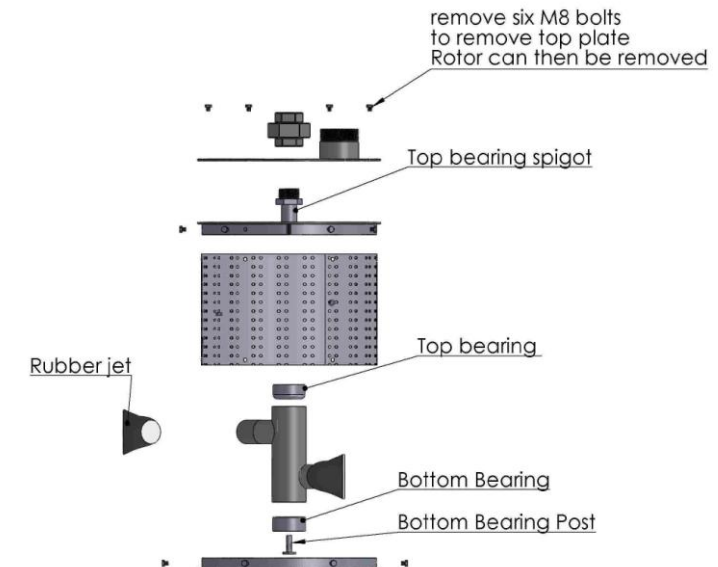

Fig 4

11.3 Bearing replacement (see fig 4 for parts identification)

There are Acetal bearings in both ends of the central rotor tube.

1. Remove the self tapping screws that hold the bearings in place.
2. Insert a long rod through the hole in the top Acetal bearing and tap the bottom bearing out.
3. Do the same for the Acetal top bearing.
4. Tap the new bearings into the tube and replace the retaining bolts.
5. The bottom bearing post is retained by a 8 mm bolt through the centre of the bottom end. Remove the 8 mm bolt and take out the old bearing post. Install the new bearing post.
6. The top bearing spigot is screwed into the 1 ½” union .
Unscrew the top bearing spigot from the union and install the new one.

12. Troubleshooting

FAULT	CAUSE	REMEDY
Filter Blocks causing pump to cavitate and /or stop pumping water	Solids levels in the water too high	If in a tank or pond with no flow, drain the tank or pond and re-fill. If solid levels persistently high reduce the pump's output . Where there is water flowing past the filter , reduce the pump's output..
	Screen is contaminated with organisms growing on the screen or detritus attached to the screen that is not removed by the backwash	Clean the screen (see 11.1, page 14)
	Rubber jets split	Replace rubber jets (see 11.2, page 15)
	Backwash Jets not rotating	Check that backwash pump is operating Bearings worn, replace bearings (see 11.3, page 16)
Filter blocked and pump will not pump water when started again.	When the filter screen is blocked, with the pump running, the differential pressure across the screen will be too great for the backwash jets to clear the screen	Stop the pump and clean the screen manually.

13. WASTE DISPOSAL

See 6.2, (page 8) for materials of construction. Remove rubber jets and acetal bearings and dispose of/recycle safely. The remainder of the filter is 304 or 316 stainless steel that can be recycled.

14. Warranty

The warranty period is 12 months from delivery.

Supply of spare parts.

Spare parts will be delivered without charge, within the warranty period, to mainland UK addresses only. If the customer exports the filter outside the United Kingdom there will be a charge for delivery of the spare parts.

Return of Filter to Rotorflush Filters Ltd.

If within the warranty period the customer returns the Filter(s), to Rotorflush Filters Ltd at the address specified in section 1.1 then Rotorflush will undertake repairs without charge.

Rotorflush will deliver the repaired Filter without charge within the warranty period to mainland UK addresses only. If the customer exports the filter outside the United Kingdom, there will be charge to return the filter to the customer

