



rotorflush

**USE AND MAINTENANCE
INSTRUCTION MANUAL
for
ROTORFLUSH FILTERS
Models RF200-A&R E's**



ROTORFLUSH Self Cleaning Inlet Filter
USE AND MAINTENANCE INSTRUCTION MANUAL
TO BE KEPT BY THE USER

1. **MANUFACTURER AND FILTER IDENTIFICATION DATA (as per EEC98/37 p. 1.7.4a)**

1.1. **Manufacturer Data**

Rotorflush Filters
Langmoor Manor
Charmouth
Bridport
Dorset
DT6 6BU
England
Telephone: +44 (0) 1297 560229
Fax: +44 (0) 1297 560110
Email: mail@rotorflush.com

1.2 **Filter Data**

Description: Submersible self cleaning Filter Models RF200-16 E
Year of manufacture: see plate on Filter

2. **TECHNICAL ASSISTANCE INFORMATION**

If a malfunction of the Filter is not covered in the TROUBLESHOOTING table contact Rotorflush Filters at the above address.

3. **INTRODUCTION**

This publication contains all necessary information and instructions for the use and maintenance of your Rotorflush Filter

Follow the advice given to ensure correct operation and optimum performance of the Filter. For any other information, please contact Rotorflush Filters.

THESE INSTRUCTIONS AND ILLUSTRATIONS ARE SUBJECT TO COPYRIGHT AND MUST NOT BE COPIED IN WHOLE OR IN PART

4. **CONTENTS**

1. **Chapter 1 – Features**
2. **Chapter 2 -Use and limitations**
3. **Chapter 3- Installation**
4. **Chapter 4 – Electrical Connections**
5. **Chapter 5 – Maintenance and trouble shooting**

5. **GENERAL SAFETY WARNINGS**

* Please pay particular attention and care to the following signs



DANGER
Electric Shock Risk

Improper use may lead to electric shock



DANGER

Improper use may cause serious injury to people or damage to property

FAILURE TO OBSERVE THESE WARNINGS AND/OR ANY TAMPERING WITH THE FILTER EXEMPTS ROTORFLUSH FILTERS FROM ALL RESPONSIBILITY IN THE EVENT OF PERSONAL INJURY OR DAMAGE TO EQUIPMENT OR PROPERTY AND/OR TO THE FILTER

Read this manual carefully and check to ensure that the Filter has been properly installed and connected in accordance with relevant safety standards before starting the Filter.

There are no RESIDUAL RISKS with Rotorflush Filters

No particular technical skills are required to use Rotorflush Filters.

No personal safety devices (precaution devices) are required to use Rotorflush Filters

5.1. Preventive Measures to be Taken by the User



a) The user must specifically comply with all the accident prevention regulations in force in the respective countries in which the Filter is being used.

b) During operation make sure that nobody is in the water

c) Before undertaking any repairs or maintenance to the Filter, isolate the electricity supply by removing the plug from the socket and/or turning off the switch (if provided). This will prevent accidental starting which could cause personal injury or damage to equipment or property.



- d) Any maintenance operation, installation or moving the Filter with the electrical system live may cause serious injury and could prove fatal.
- e) During operation, avoid moving the Filter.
- f) Before using the Filter, always check that the cable and all electrical devices are in perfect working order.
- g) When starting up the Filter (by turning on the switch, if provided, or by inserting the plug in the socket) ensure (i) you do not have wet hands (ii) you are not standing in water and (iii) you are not barefoot.
- h) The user must not carry out under his/her own initiative any operations or tasks not contemplated in this manual.

5.2. Significant Protection and Precautions

(as per EEC 98/37 p. 1.1.2 and 1.7.2; EN 292-2 p.5).

Rotorflush filters are designed so that all moving parts are shrouded by protective casings.

Rotorflush Filters declines all responsibility in the event of injury or damage caused as a result of tampering with these devices.



Each lead or live part is electrically insulated to earth; there is also a further safety device in that the accessible conductive parts are connected to an earth lead so that the parts within reach cannot become dangerous in the event of failure of the principal insulation.



Chapter1 - Features

5.3. General Description

Rotorflush filters are used for handling water containing light loads of suspended solids at temperatures up to 50°C. Unwanted solids are separated by a self-cleaning filter which is continuously backwashed with filtered water pumped through a dual-headed rotor.

Thanks to their small bulk and ease of transport, they may be used for fixed or temporary installations.

Please ensure that the Filter has not been damaged during transport, please contact the person who supplied it immediately if this is the case and do not use the filter.

Chapter 2 - Use and Limitations

CONTEMPLATED AND NON-CONTEMPLATED USE

WARNING

Failure to respect the prescribed limits constitutes a situation of use that is technically improper and may endanger the safety of persons and thus EXEMPTS ROTORFLUSH FILTERS FROM ANY RESPONSIBILITY IN THE EVENT OF ACCIDENTS TO PERSONS OR DAMAGE TO EQUIPMENT OR PROPERTY AND/OR TO THE FILTER, THEREBY RENDERING THE GUARANTEE INVALID.

Contemplated Conditions of Use

Rotorflush Filters are suitable for use with water containing light loads of suspended solids.

Max liquid temperature is 50 °C

Max immersion depth is 7 metres

Max on/off cycles/hour not to exceed 30 equally spaced per hour

Non-Contemplated Conditions of Use

Rotorflush Filters must not be installed in swimming pools and similar environment. They **must not be used** with water containing acids and corrosive liquids in general, water with temperatures over 50°C sea water, inflammable and dangerous liquids in general.

Rotorflush Filters must never be run without water.

Chapter 3 – Installation



DANGER
Risk of electric shock

When installing, please ensure the filter is disconnected from the electricity supply

Please use the handle to move or lift the Filter
Ensure that there is enough water so that the Filter will not switch on/off more than 30 times/hour, (SEE USE AND LIMITATIONS)

When the filter is used as a suction filter for a surface mounted pump, connect the suction pipe from the surface mounted pump to the 1 ¼” BSP connection on the side of the Rotorflush Filter. It is permissible to fit a non-return valve in the suction line near to the filter to assist in priming the surface mounted pumps.
The filter can be mounted in any position.

Chapter 4 – Electric Connection



Ensure that the Voltage and Frequency of the electric supply is the same as that on the rating plate on the pump. (**READ RATING PLATE**)



DANGER
Risk of electric shock

Installer must make sure that the electricity supply has an earth/ground wire conforming to the current laws



DANGER
Risk of electric shock

Make sure that the electricity supply is provided with a high sensitivity circuit breaker

 = 30mA (DIN VDE 0 100T739)

Rotorflush Filters are rated for continuous use, however it is advisable that when used as a suction filter for a surface mounted pump that they are wired so that the filter only operates when the pumps are working.



Overload Protection

The Rotorflush Filters single phase 110V and 220-240V have a built in thermal overload with automatic reset. However a correctly rated fuse or overload protection must be installed in the supply to the pump in addition to the pump's thermal protection

The Three Phase versions of Rotorflush Filters can be protected by using a magneto-thermic motor protector or a contactor with thermal relay. In either case they have to be rated conforming to the nominal power as shown on the pump rating label.

Connection Diagram (See Fig 2)

1) Start (green)	5) Supply cord	9) White
2) Run (red)	6) Grommet	10) Light Blue <line>
3) Common (black)	7) Plug	11) Brown <line>
4) Capacitor	8) Yellow-green	12) Float Switch

Chapter 5 Maintenance and Trouble Shooting

FAULT	POSSIBLE CAUSE	REMEDY
Motor does not run	<ol style="list-style-type: none"> No electricity supply Incorrect electric connection Circuit breaker has tripped Impeller Blocked Motor or capacitor damaged 	<ol style="list-style-type: none"> Check Supply Check connections Re-set circuit breaker, if it trips again call electrician Check Filter Mesh for damage. If damaged contact Rotorflush Contact Rotorflush
Motor runs but no water delivered	<ol style="list-style-type: none"> Filter Blocked Non Return Valve (if fitted) blocked 	<ol style="list-style-type: none"> Clean Filter. Reduce suspended solids in water. There is no need to dismantle the filter. Restrict pump output, filter will block less with a reduced flow through pump. Check filter mesh for damage and clean valve
Intermittent operation (single phase versions)	<ol style="list-style-type: none"> Impeller obstructed Liquid Temperature too high Motor broken 	<ol style="list-style-type: none"> Check Filter Mesh for damage. If damaged call Rotorflush Reduce temperature of liquid Contact Rotorflush

Fig. 2

A

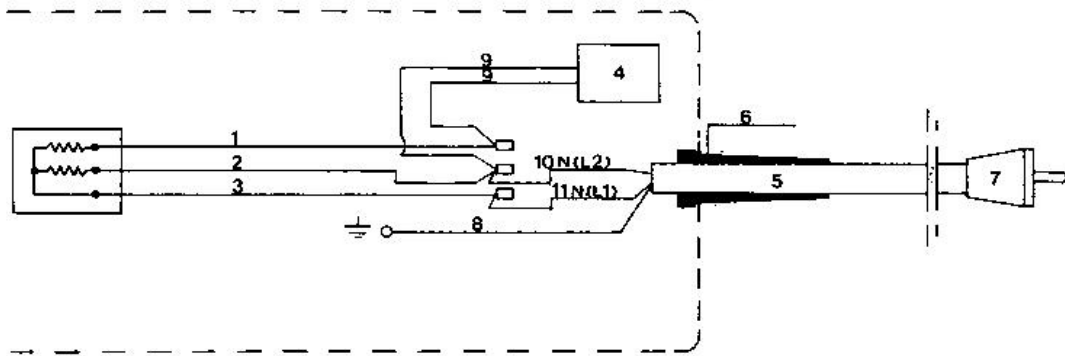

B

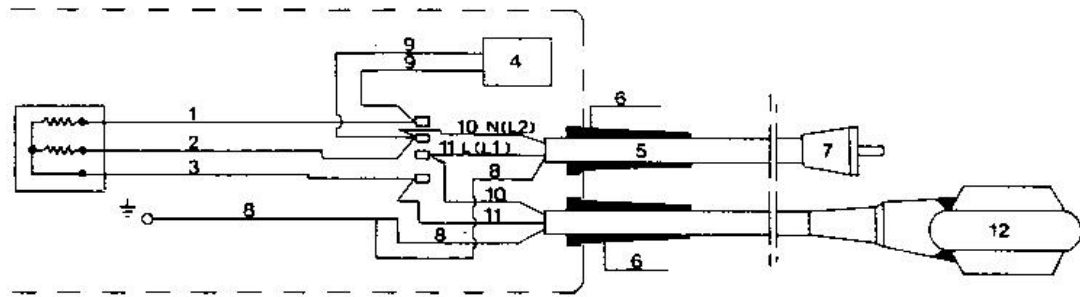

C

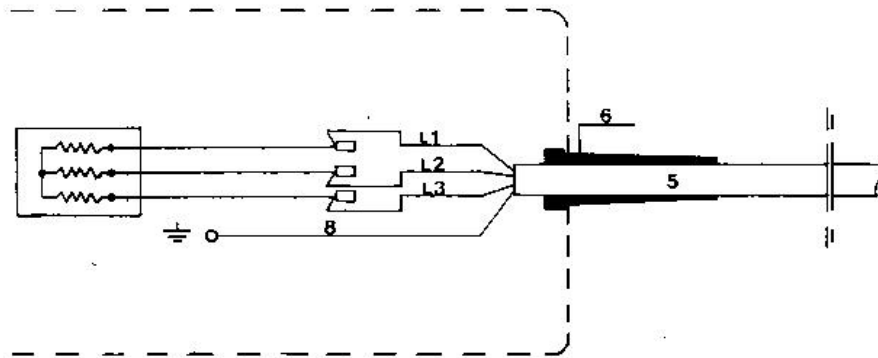

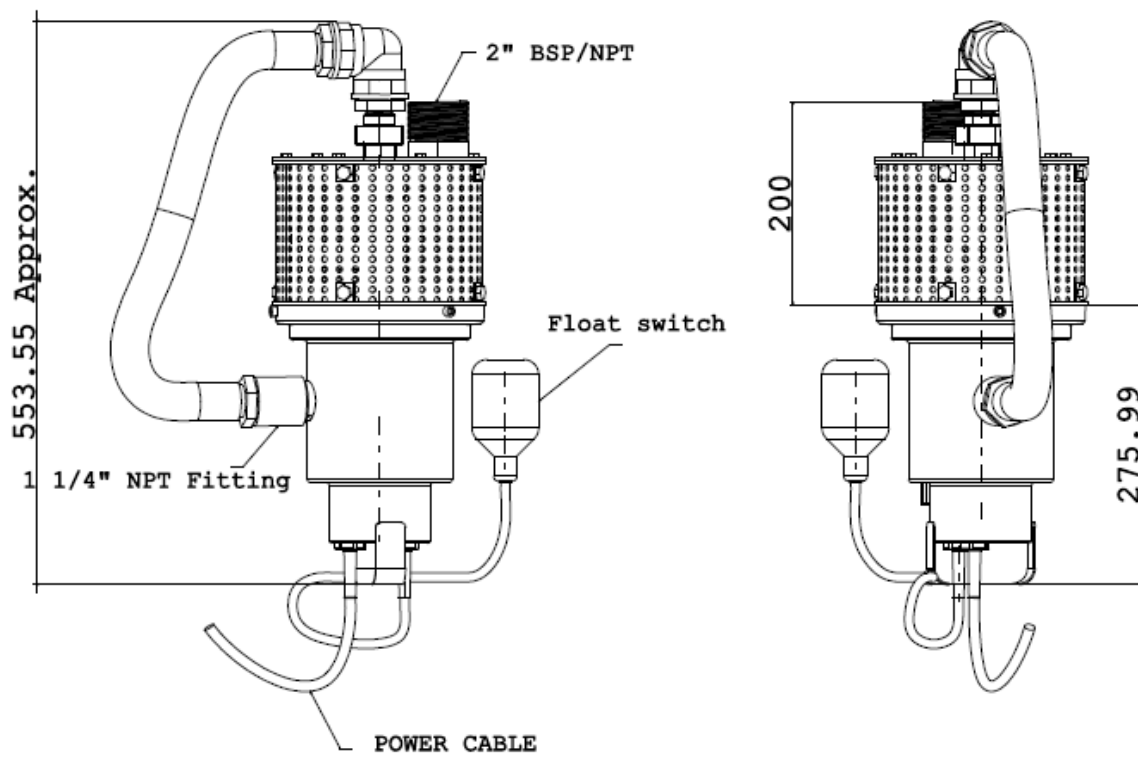

ROTORFLUSH FILTERS LTD

RF200 A/R E
(Float switch optional)

