



Product Manual

Rotorflush RF100 Duplex

Self-cleaning Suction Intake Filter

Installation Instructions

Rotorflush RF100 Duplex Self-Cleaning filter

Safety Precautions:

The relevant safety precautions must be taken with respect to the fluid that the Filter is being installed into. Factors that should be taken account of are: corrosive or poisonous liquids, poisonous or explosive gases, and bio –hazards for example bacteria, fungal spores and viruses.

When starting the pump keep well away from all pipe work so that if there are any leaks there is no possibility of coming into contact with the fluid.

Description:

The self-cleaning filter is for use as a pre-filter for pumps pumping water (2-50 °C). It is designed for attachment to the end of the suction line. It has internal cleaning rotors that continually back-flush the filter screen, removing suspended solids that are adhering to the filter screen. The cleaning rotor is powered by taking a Tee off the output of the pump.

Construction:

Filter cage	Polypropylene
Body	ABS
Cleaning Rotor	Acetal
Bearing	304 stainless steel
Filter screen	Nylon
Weight	0.5kg

Flow Rates:

The maximum usable flow through the filter, is 60 litres/min per minute with an additional 14-20 litres per minute @ 0.4-0.5 bars (backwash flow can be higher than this if required) required for the feed to the backflush rotor.

Maximum usable flow rate may be reduced depending on the total suspended solids contained in the fluid and the type of solids, (fatty/ sticky solids will reduce performance)

Dimensions:

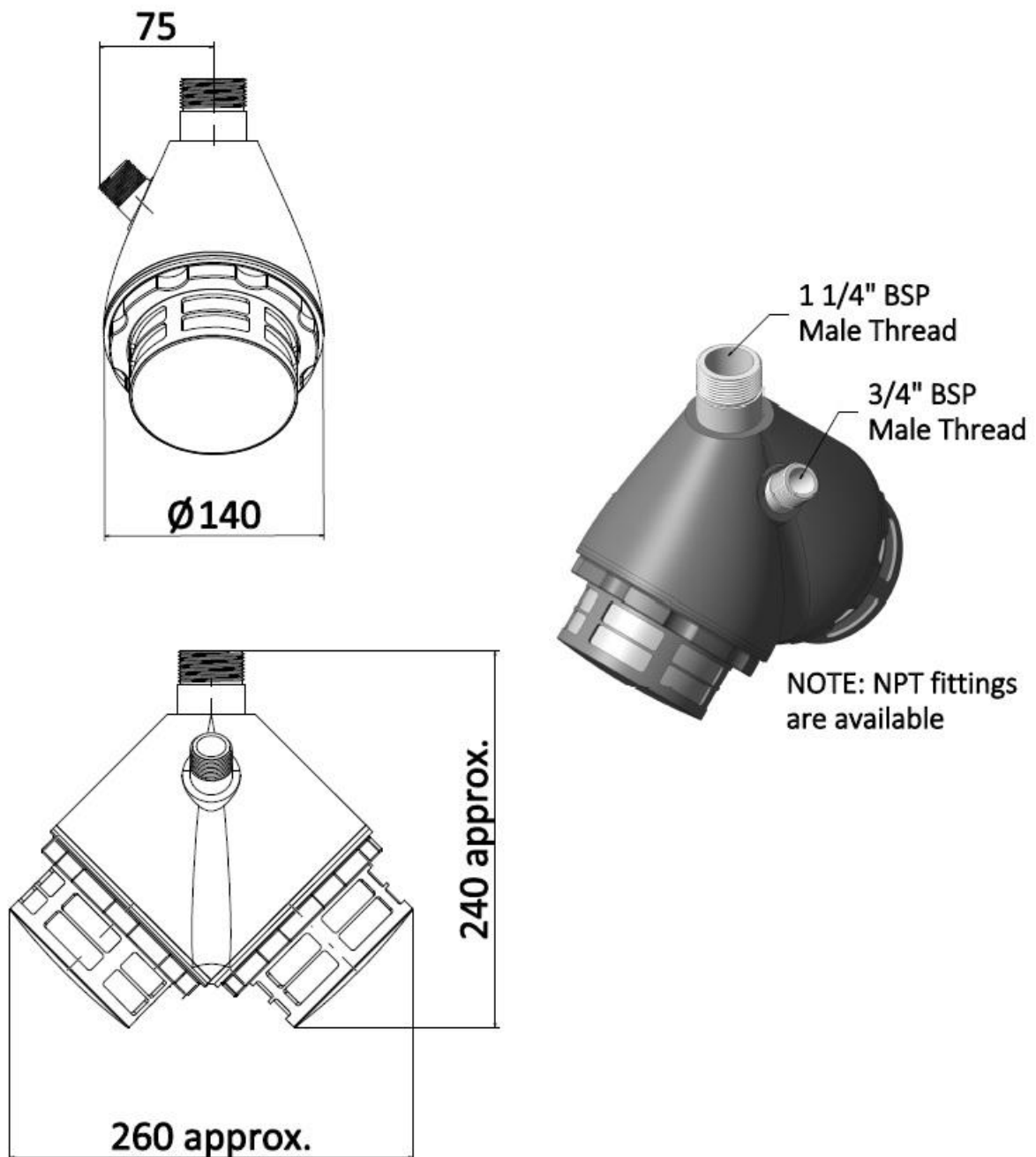

Installation:

Siting of the Rotorflush Filter.

The filter can be sited in tanks, ponds/lagoons, rivers/streams and channels/flumes where it is immersed in water.

It is very important that the detritus backwashed from the filter has sufficient space to move away from the filter.

Flowing water-when siting in flowing water, (in rivers/streams, channels/flumes, where the flow is great enough to stop settlement of solids), space around the filter is not as important.

Detritus backwashed from the filter will be carried away downstream by the flow.

When siting in a channel with flowing water, we would advise a minimum channel width of 300mm. In this situation the filter may sit on the floor of the channel as long as there are no obstructions stopping the flow of detritus away from the area of the filter.

Tanks ponds/lagoons – when siting in a tank or pond/lagoon, detritus backwashed from the filter will build up in the tank or pond/lagoon. Periodically this detritus will need to be removed.

To allow the filter to work for as long as possible in the tank before cleaning out is required, it is important that there is sufficient space around and below the filter for detritus to move away and settle.

In some circumstances the detritus may float and form a crust on the water in the tank, in this situation the filter should be sited with enough water above it so that a crust can form away from the filter.

Mounting of the Self-Cleaning Strainer:

The filter can be hung from a flexible hose

Pipe Connections

1. Connect the suction pipe from the pump to the 1¼ inch BSP connection. A 1¼ inch non- return valve should be fitted in the suction line near to the filter. It is important that when the pump is switched on water is immediately being returned to the backflushing rotor inside the filter.
2. Take a “T” off the output pipe of the pump. The return pipe from the Tee connects to the ¾” BSP connection. When the pump is switched off the upstream pipeline may drain back through the filter backwashing line. If this is a problem, fit a non- return valve upstream of the filter.
3. Prime pump and run.
4. As the amount and type of contamination in the water to be filtered is variable depending on application, a certain amount of trial and error may be required to get the balance of flow to the cleaning rotor correct. It is helpful for adjustment of the flow to fit valves on the main pump output and on the line back to the cleaning rotor so that they can be adjusted to give sufficient fluid flow back to the cleaning rotor to keep the filter screen clean in the prevailing conditions.

RF100 DUPLEX Pipe Diagram

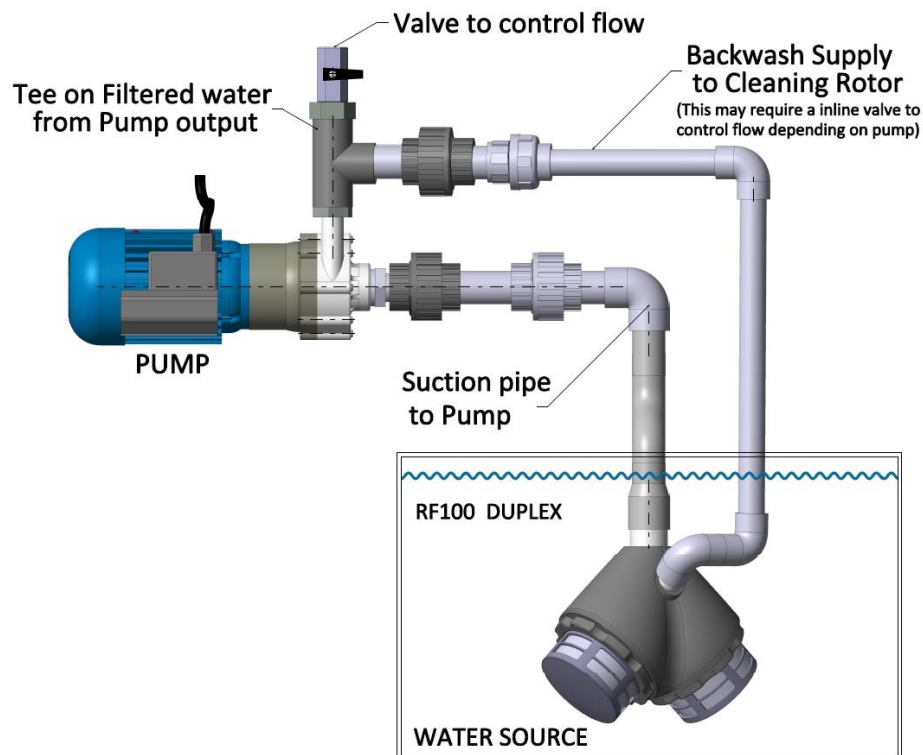

Maintenance:

Replacing the Filter Mesh

Over a period of time the filter head may become blocked with detritus that cannot be removed by the backwash mechanism. The filter can be gently cleaned or rinsed (do not use a high pressure hose).

The Filter cage should be replaced every 6 months - replacements are available from Rotorflush Filters Ltd. Please quote the part number when ordering.

60 micron filter mesh cages are Part no. RF-096.

115 micron filter mesh cages are Part no. RF-097

250 micron filter mesh cages are Part no. RF-098

In most conditions the filter will only need maintenance every 6 months. However if there is a lot of detritus in the water to be filtered, particularly if it contains fatty, oil, or sticky substances or if there is excessive biological growth then the filter cage may need to be cleaned or changed more frequently.

Removing the Filter Head

1. Unscrew the filter cage and Quick Release nut from the body of the filter
2. Remove the filter cage from the Quick Release nut
3. Fit the new filter cage into the Quick Release nut
4. Screw the Quick Release Nut and cage onto the filter body. Do not over tighten hand tight is sufficient.

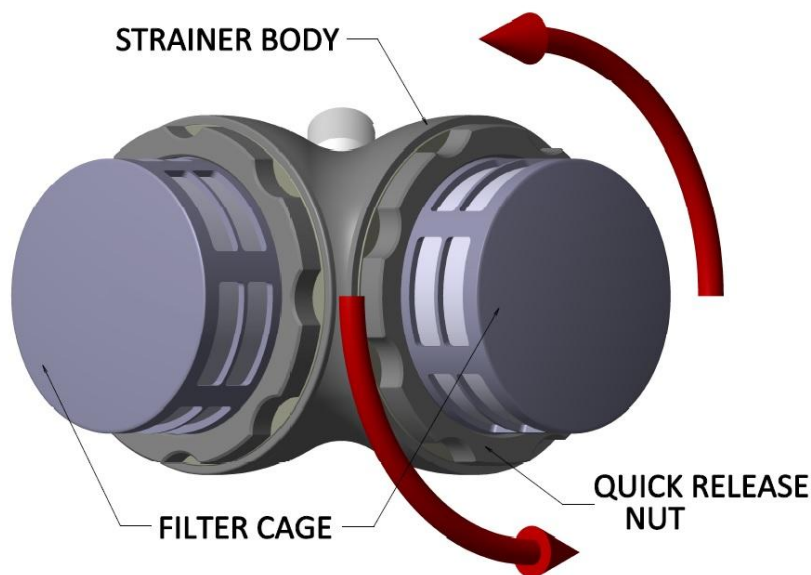



NOTES