

ROTORFLUSH FILTERPUMPS

Cobalt 400 Range Models:

CKC31.5 400AR CKC32.2 400AR CKC42.2 400AR

USE AND MAINTENANCE INSTRUCTION MANUAL

TO BE KEPT BY THE USER

For three phase pumps it is imperative that electrical connections are made so that the Filterpump “KICKS” in the correct direction. If the pumps are run in the wrong direction for more than a few seconds serious damage may result which will invalidate the guarantee.

Read paragraph 9.3 before installation for the method of checking correct direction of rotation.

Although the filters are self-cleaning there may over time be a build-up of detritus in the pores of the mesh which the self-cleaning mechanism cannot remove.

For stainless steel filter mesh use a pressure washer to very thoroughly clean the outside of the mesh.

For nylon screens either clean low pressure water or replacement inserts are available from Rotorflush Filters Ltd.

If the pump is run with the filter screen clogged it may cause the pump to overheat and seriously damage the motor invalidating the guarantee. The use of appropriate cos phi load monitoring and dry running protection is essential with all models.

In most conditions the filter should be inspected every 2 months. In some situations it may require more frequent inspection and if required cleaning.

Stainless steel screens should be thoroughly cleaned with a pressure washer. Nylon screens should be cleaned with gentle running water or replaced. It is recommended that nylon screens are replaced at these intervals:

Nylon screens:	300 micron every 5000 hours of use or every year.
Fine Stainless steel screens	315 micron every 5000 hours of use or every year. 1mm mesh pressure washed 6 monthly.
Coarse stainless steel screens	Greater than 1mm - pressure washed at least every year

NB: Maintenance is estimated on averagely dirty raw water conditions. Water quality, and therefore maintenance intervals, can vary greatly

Contents

1.	MANUFACTURER & PRODUCT IDENTIFICATION DATA (as per EEC98/37 p.1.7.4a)	3
1.1.	Manufacturer Data	3
1.2.	Filterpump Data	3
2.	TECHNICAL ASSISTANCE INFORMATION	3
3.	INTRODUCTION	3
4.	GENERAL SAFETY WARNINGS.....	4
4.1.	Preventive Measures to be taken by the User	4
4.2.	Significant Protection and Precautions (as per EEC 98/37 p. 1.1.2 and 1.7.2; EN 292-2 p.5).	4
5.	DESCRIPTION	5
5.1.	General Description	5
5.2.	Technical and Construction Characteristics	5
6.	TECHNICAL DATA CARD (as per EEC 98/37 p.1.1.2 and 1.7.2; EN 292-2 p.....	5
6.1.	Pump Technical Data	5
6.2.	Self-cleaning Filter Technical Data	5
7.	CONTEMPLATED AND NON-CONTEMPLATED USE	6
7.1.	Contemplated Conditions of Use.....	6
7.2.	Non-Contemplated Conditions of Use.....	6
8.	HANDLING AND TRANSPORT (as per EEC 98/37 p. 1.7.4.a; EN 292-2 p.5 1.1.a)	6
8.1.	Unpacking	6
8.2.	Handling and De-installing.....	6
8.3.	Transport	7
9.	PREPARATION FOR USE (as per EEC 98/37 p.1.7.4.a, EN 292-2 p.5.1.3).....	7
9.1.	General information	7
9.2.	Electrical Connections.....	7
9.3.	Checking the Direction of Rotation.....	7
10.	INSTALLATION (as per EEC 98/37 p. 1.7.4.a; EN 292-2 p.5.1.1b)	7
10.1.	Fixed Installation	8
10.2.	Temporary Installation (for Temporary Use)	9
11.	ASSEMBLY AND DISASSEMBLY (as per EEC 98/37 p.1.7.4.a).....	9
12.	ADJUSTING AND REGISTERING (as per EEC 98/37 p.1.7.4.a; EN 292-2 p.5.5.1.d).....	9
13.	USE AND START-UP (as per EEC 98/37 p.1.7.4.a; EN 292-2 p. 5.5.1.d)	10
13.1.	Starting.....	10
14.	MAINTENANCE AND REPAIRS (as per EEC 98/37 p.1.6; EN 292-2 p.5.5.1.e)	10
14.1.	Troubleshooting.....	11
15.	TECHNICAL INFORMATION	12
15.1.	Diagram of Filterpump Dimensions and Weights	12
15.2.	Diagram for Installation with Minimum Functional Distances	12
15.3.	Rating Plate Example	13
16.	INFORMATION ON AIR-BORNE NOISE (as per EEC 89/392 p. 1.7.4.f).....	14
17.	WASTE DISPOSAL.....	14
18.	DECLARATION OF CONFORMITY	14

ROTORFLUSH FILTERPUMPS
Cobalt Models CKC31.5 400AR, CKC32.2 400AR & CKC42.2 400AR

1. MANUFACTURER & PRODUCT IDENTIFICATION DATA (as per EEC98/37 p.1.7.4a)

1.1. Manufacturer Data

Rotorflush Filters
Langmoor Manor
Charmouth
Bridport
Dorset
DT6 6BU
England

Telephone: +44 (0) 1297 560229

Fax: +44 (0) 1297 560110

Email: mail@rotorflush.com

1.2. Filterpump Data

Description: Submersible Pump with integral Self-cleaning Intake screen. Referred to as a 'Filterpump' within this document.

Cobalt Models: CKC31.5 400AR CKC32.2 400AR CKC42.2 400AR

2. TECHNICAL ASSISTANCE INFORMATION

If a malfunction of the Filterpump is not covered in the TROUBLESHOOTING table (Section 14.1) contact Rotorflush Filters at the above address.

3. INTRODUCTION

This publication contains all necessary information and instructions for the use and maintenance of your Rotorflush Filterpump.

Follow the advice given to ensure correct operation and optimum performance of the Filterpump. For any other information, please contact Rotorflush Filters

***THESE INSTRUCTIONS AND ILLUSTRATIONS ARE SUBJECT TO COPYRIGHT AND MUST NOT BE COPIED IN
WHOLE OR IN PART***

4. GENERAL SAFETY WARNINGS

FAILURE TO OBSERVE THESE WARNINGS AND/OR ANY TAMPERING WITH THE FILTERPUMP EXEMPTS ROTORFLUSH FILTERS FROM ALL RESPONSIBILITY IN THE EVENT OF PERSONAL INJURY OR DAMAGE TO EQUIPMENT OR PROPERTY AND/OR TO THE FILTERPUMP

Read this manual carefully and check to ensure that the Filterpump has been properly installed and connected in accordance with relevant safety standards before starting the Filterpump.

There are no RESIDUAL RISKS with Rotorflush Filterpumps.

No particular technical skills are required to use Rotorflush Filterpumps, although installation should be carried out by a qualified electrician.

No personal safety devices (precaution devices) are required to use Rotorflush Filterpumps.

4.1. Preventive Measures to be taken by the User



a) The user must specifically comply with all the accident prevention regulations in force in the respective countries in which the Filterpump is being used; the indications given in Section 7 must be scrupulously followed.



b) During operation make sure that nobody is in the water

b) Before undertaking any repairs or maintenance to the Filterpump, isolate the electricity supply by removing the plug from the socket and/or turning off the switch (if provided). This will prevent accidental starting which could cause personal injury or damage to equipment or property.

c) Any maintenance operation, installation or moving the Filterpump with the electrical system live may cause serious injury and could prove fatal.

e) During operation, avoid moving the Filterpump.

f) Before using the Filterpump, always check that the cable and all electrical devices are in perfect working order.

g) When starting up the Filterpump (by turning on the switch, if provided, or by inserting the plug in the socket) ensure (i) you do not have wet hands (ii) you are not standing in water and (iii) you are not barefoot.

h) The user must not carry out under his/her own initiative any operations or tasks not contemplated in this manual.

4.2. Significant Protection and Precautions (as per EEC 98/37 p. 1.1.2 and 1.7.2; EN 292-2 p.5).



Rotorflush Filterpumps are designed so that all moving parts are shrouded by protective casings. Rotorflush Filters Ltd declines all responsibility in the event of injury or damage caused as a result of tampering with these devices.



Each lead or live part is electrically insulated to earth; there is also a further safety device in that the accessible conductive parts are connected to an earth lead so that the parts within reach cannot become dangerous in the event of failure of the principal insulation.

5. DESCRIPTION

5.1. General Description

Rotorflush Cobalt 400 Series Filterpumps are all similar from the functional and constructive point of view; the only differences are the following:

- Power
- Flow rate
- Head
- Weight
- Dimensions

Rotorflush Cobalt Filterpumps are used for handling water containing total suspended solids not greater than 2,000 mg/litre dry weight at temperatures up to 40°C (Section 7.1). Unwanted solids are separated by a self-cleaning filter which is continuously backwashed with filtered water pumped through a dual-headed rotor by a secondary impeller mounted on an extended impeller shaft attached to the pump.

Thanks to their relatively compact bulk and ease of transport, they may be used for fixed or temporary installations, with or without automatic start.

Rotorflush Filterpumps are designed for long life and constant performance if used according to the instructions given in Sections 8, 10 and 15.

5.2. Technical and Construction Characteristics

Rotorflush Filterpumps are designed and built to the following design and construction standards:

Machine 98/037/EEC; EN292 standard

Low Voltage 73/23/EEC and relative additions EN60335-1 and EN 60335-2-41 standards

Electromagnetic Compatibility 89/336/EEC and relative additions EN50081-1 and 2 standards

6. TECHNICAL DATA CARD (as per EEC 98/37 p.1.1.2 and 1.7.2; EN 292-2 p.

6.1. Pump Technical Data

The Cobalt CKC31.5 400AR, CKC32.2 400AR and CKC42.2 400AR filterpumps are based on submersible general dewatering pumps.

6.2. Self-cleaning Filter Technical Data

Filter Mesh Area	2510 cm ²
Filter Mesh	Stainless steel 100 or 315 microns; Stainless Steel woven mesh 1, 1.5 or 2mm Perforated stainless steel mesh 3mm or 6mm
Materials: Filter cage	Stainless Steel
Backwash rotor	Acrylonitrile Butadiene Styrene (ABS)
Rotor thrust bearing	Silicon Carbide
Rotor impeller	AISI304 Stainless Steel
Rotor impeller extension shaft	AISI304 Stainless Steel

7. CONTEMPLATED AND NON-CONTEMPLATED USE

WARNING

Failure to respect the prescribed limits constitutes a situation of use that is technically improper and may endanger the safety of persons and thus EXEMPTS ROTORFLUSH FILTERS FROM ANY RESPONSIBILITY IN THE EVENT OF ACCIDENTS TO PERSONS OR DAMAGE TO EQUIPMENT OR PROPERTY AND/OR TO THE FILTERPUMP, THEREBY RENDERING THE GUARANTEE INVALID.

7.1. Contemplated Conditions of Use

Rotorflush Filterpumps are suitable for pumping water, non-aggressive and compatible with materials used to construct the pump. Max density 1.1 kg/dm³ with a total suspended solids loading not exceeding 2000mg/litre dry weight. Oily/fatty/sticky solids will reduce filter performance. They can be used with pressurisation units. Use the Filterpump in keeping with its technical characteristics (Section 7).

7.2. Non-Contemplated Conditions of Use

Rotorflush Filterpumps must not be installed in swimming pools, garden ponds and similar environments where and when people are in the water. For pumping fluids having total suspended solids loading of more than 2,000 mg/litre dry weight. **Rotorflush Filterpumps must never be run without water.**

8. HANDLING AND TRANSPORT (as per EEC 98/37 p. 1.7.4.a; EN 292-2 p.5 1.1.a)

8.1. Unpacking

Check that there are no breakages or severe dents in the packing; if there are, point this out immediately to the person who delivers the material. After removing the Filterpump from the package, check that it has not suffered any damage during transit; if damage is found, inform the dealer within 8 days of delivery. Check that the specifications stated on the plate of the Filterpump are the same as you requested in your order.

8.2. Handling and De-installing



WARNING



FAILURE TO FOLLOW THESE INSTRUCTIONS MAY CAUSE THE FILTERPUMP TO FALL AND SUFFER SEVERE DAMAGE. NEVER UNDER ANY CIRCUMSTANCES USE THE POWER CABLE TO LIFT OR DRAG THE FILTERPUMP. USE THE CORRECT LIFTING GEAR REQUIRED FOR WEIGHT IN EXCESS OF 65 KGS DRY WEIGHT

To handle or de-install the Filterpump you must:

- remove the plug from the power socket and/or switch off the switch, if provided;
- roll up and hold the electric power cable to avoid cable damage;
- lift the Filterpump and the delivery pipe using appropriate PPE and lifting gear.

If the Filterpump is set up for fixed applications, perform the following operations before handling it:

- remove the plug from the power socket and/or switch off the switch, if provided;
- unscrew any clamps and remove the delivery pipe;
- roll up and hold the electric power cable to avoid cable damage;
- lift the Filterpump and the delivery pipe using appropriate PPE and lifting gear.

8.3. Transport

The Filterpump is packed on a pallet for transport; check the gross weight before moving or transporting these Filterpumps

9. PREPARATION FOR USE (as per EEC 98/37 p.1.7.4.a, EN 292-2 p.5.1.3).

9.1. General information



Before beginning to work on the electrical pump, make sure that you have disconnected the electricity from the power supply mains and that it cannot be accidentally reconnected.

The voltage variation allowed +/- 5% (3-phase 380-415 V)

9.2. Electrical Connections

Connections must only be performed by an authorised electrician in compliance with the law in force. Verify that the data on the name plate match the nominal values for the power line. Make the connection after verifying the existence of a working grounding circuit.



It is the Installer's responsibility to perform the connection in compliance with regulations in force in the country of installation.

The 3-phase versions need external protection (rapid disconnect magnetic overload cut-out) with intervention time calibrated to:

- Less than 10 seconds with 5 times IN
- Less than 10 minutes with 1.5 times IN

IN = maximum value of current shown on the name plate

The installation of a differential switch is highly recommended

9.3. Checking the Direction of Rotation

After connecting the power supply, the direction of rotation can be inverted in the three phase versions; in this case performance will be significantly lower than the nominal values **and will cause substantial damage to the Filterpump if run in the wrong direction for more than a few seconds and will invalidate any guarantee.**

To verify a correct connection, proceed as follows:

Start the pump before it is installed. By reaction, it must tend to rotate ("kick") in an **ANTI-CLOCKWISE** direction viewed from above (discharge end).

CAUTION! This operation will be performed dry and must not last more than a few seconds.

10. INSTALLATION (as per EEC 98/37 p. 1.7.4.a; EN 292-2 p.5.1.1b)

WARNING

TO LIFT OR LOWER THE FILTERPUMP, USE A STRONG ROPE OR CHAIN AND APPROPRIATE LIFTING GEARFIXED TO THE EYELETS; NEVER USE THE ELECTRIC POWER CABLE.

Before beginning to work on the electrical pump make sure that you have disconnected the power supply from the power supply mains and that it cannot be accidentally reconnected.

The installation of the electrical pump can involve a certain amount of complexity. For this reason, it must be performed by competent and authorised installers.

The Delivery Pipe

The diameter of the delivery pipe depends on the flow rate and pressure available at the points of use. For installations with long lengths of delivery pipe, friction loss can be reduced by using a pipe diameter larger than the discharge outlet of the pump. It is advisable to install a check valve after the discharge outlet to avoid dangerous water hammers in the event the electrical pump should stop suddenly. Do not use excessive force when connecting the pipe to the discharge outlet in order to avoid damage. The electrical pump can be installed for use with either a metal pipe (which can be used to support the pump) or flexible tubing. In the latter case the electrical pump must be supported by a cable made of a material with long lasting resistance, passing through the eyelets at the top of the pump. Fix the power cable to the delivery pipe using suitable straps.

CAUTION! Do not underestimate the risk of drowning if the installation must be performed in a well of a certain depth. Make sure there is no danger of toxic vapours or harmful gases in the work atmosphere.

10.1. Fixed Installation

We strongly recommend that the pump is fitted with dry run protection, so that if the filter blocks for any reason or there is insufficient water the pump is automatically stopped to prevent damage from dry running

10.1.1. The Filterpump may be installed upright or horizontally although the self-cleaning filter will work better in the upright position.

10.1.2. The Filterpump should be fully submerged if possible although this is not necessary except for frost protection. The Filterpump will operate continuously if at least 450mm of the filter unit and suction end of the pump are submerged in water at a temperature of less than 40°C.

There must be a gap of at least 200mm around and 100mm underneath the filter unit, although there is no need for a gap under the Filterpump when operated in the upright position if there is a flow of fluid past the filter pump to take detritus away from the screen (e.g. when installing in a flowing river or flume the filter unit at the suction end of the Filterpump) at all times to allow solid particles to fall or be washed clear of the filter screen. Due allowance must be made to allow for any build-up of solids underneath the filter and any detritus, sludge etc. must be removed from time to time to ensure this does not come within 100mm of the filter.

When lowering the Filterpump into a well or tank, ensure that it is at least 100mm above the bottom.

Be careful with the power cable when lowering the Filterpump. It is advisable to tie the power cable to the delivery pipe every two or three metres.

10.1.3. When positioning the Filterpump, observe the minimum required distances (fig. 2) from walls, from the sides of the drain, tank or other location, so as to allow functioning, use and maintenance operations in safe conditions (as per EN 292-2 p.5.5.1.b).

10.1.4. It is recommended that standard size rigid pipes (metal or plastic) be attached to the Filterpump with clamps of a suitable size.

10.1.5. Anchor the pipes to the edge of the basin or tank with a pipe clamping bracket.

10.1.6. If there is the need to install a non-return valve onto the delivery pipes, make sure it is placed away from the Filterpump filter screen to avoid priming problems when first starting or after emptying.

10.2. Temporary Installation (for Temporary Use)

10.2.1. The Filterpump may be installed upright or horizontally. (As above).

The Filterpump should be fully submerged if possible (as above) but it will operate continuously if at least 450mm of the filter unit and suction end of the pump are submerged in water at a temperature of less than 40°C

- 10.2.2.** There must be a gap of at least 200mm around and 100mm underneath the filter unit, although there is no need for a gap under the Filterpump when operated in the upright position if there is a flow of fluid past the filter pump to take detritus away from the screen (e.g. when installing in a flowing river or flume at the suction end of the Filterpump) at all times to allow solid particles to fall or be washed clear of the filter screen. Due allowance must be made to allow for any build-up of solids underneath the filter and any detritus, sludge etc. must be removed from time to time to ensure this does not come within 100mm of the filter.
- 10.2.3.** When lowering the Filterpump into a well or tank, ensure that it is at least 100mm above the bottom.
- 10.2.4.** Be careful with the power cable when lowering the Filterpump. It is advisable to tie the power cable to the delivery pipe every two or three metres.
- 10.2.5.** When positioning the Filterpump, observe the minimum required distances (fig. 2) from walls, from the sides of the drain, tank or other location, so as to allow functioning, use and maintenance operations in safe conditions (as per EN 292-2 p.5.5.1.b).
- 10.2.6.** It is recommended that standard size rigid pipes (metal or plastic) be attached to the Filterpump with clamps of a suitable size.
- 10.2.7.** If there is the need to install a non-return valve onto the delivery pipes, make sure it is placed away from the Filterpump filter screen to avoid priming problems when first starting or after emptying.

11. ASSEMBLY AND DISASSEMBLY (as per EEC 98/37 p.1.7.4.a).

The basic Filterpump has no separate parts or accessories, so no assembly is required for installation. If the Filterpump is to be used with the Rotorflush Valve Control System, the assembly instructions provided with the Control Valve system must be followed.

The user must not attempt to disassemble any other component not covered in these instructions and should contact Rotorflush Filters for advice if any further disassembly is required.

FAILURE TO COMPLY WITH THIS RULE RENDERS THE GUARANTEE INVALID.

12. ADJUSTING AND REGISTERING (as per EEC 98/37 p.1.7.4.a; EN 292-2 p.5.5.1.d)

The only thing that needs checking once installation is complete is the length of the cable with float (in installations that have one) with respect to the minimum and maximum water level.

13. USE AND START-UP (as per EEC 98/37 p.1.7.4.a; EN 292-2 p. 5.5.1.d)

The water level must never be lower than the filter screen, even when the pump is not being used. If you fail to observe this, the Filterpump will run out of water and you will have great difficulty starting the Filterpump again.

13.1. Starting



Never continuously run the Filterpump until it is placed and installed in its final operational position. It is possible to have leakage of the Filterpump oil into the pumped liquid; however, this is not harmful to health.

To start up the Filterpump, connect the plug and/or turn on the switch. When the water level reaches the minimum level (fig. 2), disconnect the plug and/or turn off the switch.

14. MAINTENANCE AND REPAIRS (as per EEC 98/37 p.1.6; EN 292-2 p.5.5.1.e)

BEFORE CARRYING OUT ANY MAINTENANCE OPERATIONS, DISCONNECT THE PLUG AND/OR SWITCH OFF.

FOR ANY REPAIR JOBS DURING THE GUARANTEE PERIOD, THE USER MUST CONTACT ROTORFLUSH FILTERS



FAILURE TO OBSERVE THIS RULE RENDERS THE GUARANTEE INVALID.

AFTER THE GUARANTEE PERIOD, ALL MAINTENANCE OPERATIONS, REPAIR JOBS AND/OR REPLACEMENTS, MUST BE CARRIED OUT BY SKILLED TECHNICIANS ONLY.

To ensure correct functioning and long life of the Filterpump, the Rotorflush filter unit should be inspected and every two – six months, depending on mesh type and water conditions. The amount of cleaning required will depend on the liquid being pumped in some instances more frequent manual cleaning of the filter screen may be required, for example where biological growth occurs on the filter screen or oily/fatty deposits are found to build up on the filter screen).

Stainless steel screens should be thoroughly cleaned with a pressure washer. Nylon screens should be cleaned with gentle running water or replaced. It is recommended that nylon screens are replaced at these intervals for use in average conditions. Maintenance intervals will vary according to water quality and use.

Nylon screens: 300 micron every 5000 hours of use or every year. 115 nylon and 60 micron every 1000 hours of use or 6 monthly whichever occurs first.

Stainless steel screens: These should be pressure washed at least every year, but may be more frequently depending on conditions.

Check the condition of the electric power cable; if it is damaged, contact the dealer or Rotorflush Filters Ltd to have it replaced.

14.1. Troubleshooting
TYPE OF FAULT: The pump does not work (the motor does not turn over)

CAUSE	REMEDY
No electric power	Check the contactor on the electric line
Plug not inserted	Check power connection to the line
Automatic switch has tripped	Reset the switch and check the cause
Thermal protection has tripped	This resets automatically
Protection fuses are burnt out (three-phase)	Replace the fuses with same type
Faulty motor	Contact Rotorflush Filters

TYPE OF FAULT: The pump does not work (the motor turns over)

CAUSE	REMEDY
Intake filter blocked	Clean the filter / replace mesh inserts
Non-return valve blocked	Clean the valve and check its operation
The pump does not start up	Check minimum water level Check function of delivery gate valve
Hole in filter screen causing pump to block with detritus	Return to Rotorflush Filters for repairs

14.1. Troubleshooting continued

TYPE OF FAULT: The pump works at a low flow rate

CAUSE	REMEDY
Dirty deliver pipe	Clean pipe
Clogged filter screen	Clean, if continues to be a problem, fit control valve (available from Rotorflush Filters)
Dirty Impellers	Check filter screen for damage. If damaged contact Rotorflush Filters for replacement screen)
Non-return valve blocked	Clean the valve and check its operation
Water level too low	Switch off the pump
Wrong direction of rotation	Check the direction of rotation (three-phase only, section 9.3)
Wrong supply voltage	Feed the pump with the voltage indicated on the rating plate

TYPE OF FAULT: The pump stops after brief periods of operation (tripping the thermal protection)

CAUSE	REMEDY
Liquid temperature too high	The temperature exceeds the technical limits of the pump
Internal defect	Contact Rotorflush Filters

15. TECHNICAL INFORMATION

15.1. Diagram of Filterpump Dimensions and Weights

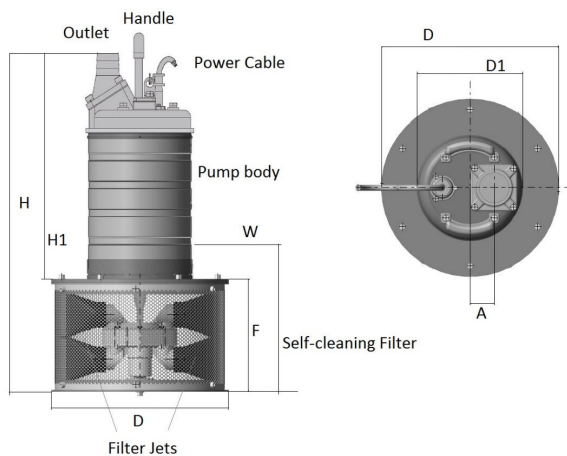
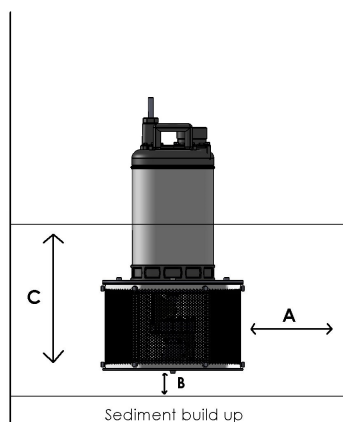

Figure 1

Cobalt 400 Range Approximate Dimensions and Weight

Rotorflush Model	Min Water Level 'W'	Filter Height 'F'	Filter Diameter 'D'	Total Height 'H'	Pump Body Diameter 'D1'	Dry Weight Kgs
CKC31.5 400AR	450mm	270mm	420mm	745	262	65
CKC32.2 400AR	450mm	270mm	420mm	745	302	65
CKC42.2 400AR	450mm	270mm	420mm	765	302	70

15.2. Diagram for Installation with Minimum Functional Distances



A. 200mm min gap to side of tank

B. 100mm min gap to top of sediment or detritus at bottom of tank

C. 450mm minimum immersion from bottom of filter

15.3. Rating Plate Example



ROTORFLUSH FILTERS
Langmoor Manor
Charmouth, DT6 6BU, UK
0044 (0) 1297 560229
Patents granted

Made in UK
2015

TYPE FILTERPUMP (1)		FPE (2)	
Qmax. (2) m ³ /min (3)	N Min ⁻¹ (14)	H max m (5)	
U V (6)	- I A (11)	H min m (7)	
DN mm (4)	Phase (13)	P1 kW (12)	P2 kW (8)
T max °C (15)	Ins. F (19)	HP (9)	▼ (18) m
Hz (10)		IP (17)	
Weight Kg (20)	P/N FIL (21)		

KEY:

(1)	Model	(11)	"A"	Nominal current
(2)	Serial Number	(12)	"P1"	Input power
(3)	"Q"	(13)	"Phase"	Type of motor (single or three phase)
(4)	"DN"	(14)	"min-1"	Revolution speed
(5)	"Hmax"	(15)	"TMAX"	Maximum water temperature
(6)	"V~"	(17)	"IP"	Protection classification
(7)	"Hmin"	(18)	"m"	Max operational depth
(8)	"P2"	(19)	"Ins. C. F S1"	Insulation class and duty type
(9)	"HP"	(20)	"Weight"	Weight
(10)	"Hz"	(21)	"P/N"	Part number

16. INFORMATION ON AIR-BORNE NOISE (as per EEC 89/392 p. 1.7.4.f)

The weighted sound pressure level A produced by the Filterpump does not exceed the value of 70 dB (A)

17. WASTE DISPOSAL

Before scrapping the Filterpump, make sure the lubricating oil is separated from the other components.
Do not dump lubricating oil in the environment. It must be disposed of properly.

18. DECLARATION OF CONFORMITY

DECLARATION OF CONFORMITY

We, ROTORFLUSH FILTERS LIMITED, declare under our own responsibility that our products Filterpump Jasper T22-400R, T37-400R, T55-400R & T-75-400R conform to the Machinery Directive 89/392/CEE as modified by Directives 91/368/CEE, 93/44/CEE, 93/68/CEE, to the Low Tension Directive 73/23/CEE, as modified by Directive 93/68/CEE and to the Electromagnetic Compatibility Directive 89/336/CEE as modified by Directive 93/68/CEE.

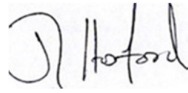

J Hosford
Proprietor Rotorflush Filters

Notes